

FINAL CONCEPT REPORT

Hollenbeck Park Lake Rehabilitation and Stormwater Management

Prepared for

City of Los Angeles Bureau of Sanitation

August 2, 2016



1000 Wilshire, Suite 2100
Los Angeles, California 90017

Executive Summary

Project Overview

Hollenbeck Park is an urban park in Boyle Heights within Los Angeles Council District 14 that provides aesthetic and recreational public uses for the community. The park is centered on Hollenbeck Park Lake (HPL), a 4.3-acre manmade urban water body that serves as an attractive water feature for public enjoyment. HPL is highly valued by the community as a recreational asset where green space is rare.

The purpose of this Conceptual Design Report for the Hollenbeck Park Lake Rehabilitation and Stormwater Management Project (the Project) is to evaluate alternatives for a holistic stormwater approach that integrates improvements at HPL with new and proposed nearby downstream facilities located at the 6th Street Viaduct Replacement Project and the intersection of Mission Road and Jesse Street. A major component of a sustainable stormwater solution will be replacing potable water with an alternative source to meet the water needs at HPL and downstream facilities within the watershed.

The Project concept is intended to achieve the following objectives:

- Replace 74.1 acre-feet per year (24.1 million gallons) of potable water supply at HPL and downstream facilities with an alternative, sustainable water source
- Improve water quality and control algae at HPL
- Restore HPL's appearance and provide a long-term solution to erosion around the lake's edge
- Provide treatment/management of dry/wet weather flow in the watershed
- Harvest stormwater and reuse for irrigation and other water demands

Water Supply Alternatives

Four alternative sources of water were considered to replace the potable water for the Project, including the Los Angeles River, Los Angeles Department of Water and Power (LADWP) recycled water, sewer mining, and non-stormwater/stormwater flow diversion. Seasonal water demands for each component of the Project were calculated. The annual water demand for the Project totals 74.1 acre-feet per year.

The LADWP recycled water supply alternative supplemented with diverted dry weather and stormwater flows was found to be the most favorable alternative for replacing potable water based on water quality benefits of treating dry/wet weather flow, lower capital cost, reduced operations and maintenance from LADWP pipeline ownership, and recycled water quality already meets irrigation standards.

Hollenbeck Park Lake Issues

HPL has a history of water quality concerns attributable to nutrient and sediment loading as well as site-specific factors. Visually, one can readily discern that HPL water is turbid, with a limited transparency of 1 to 2 feet, indicating the presence of high populations of algal cells. Given that two decades have passed since the operation of the treatment systems installed at HPL, with the exception of the fountain recirculation system, available information indicates that sediment has deepened and that internal cycling of nitrogen and phosphorus from the sediments to the water column continues within HPL. This situation has elevated the algal populations and contributed to a deterioration in lake water quality through eutrophication and a decrease in dissolved oxygen.

There is also extensive erosion around the perimeter of HPL, most notable along the vegetated areas between the lake edge and existing pedestrian walkway. Erosion has also begun to undermine the existing pavement, compromising visitor safety by creating falling and tripping hazards. The erosion is likely a result of the steep slopes around the lake, which produce erosive velocities for stormwater and irrigation runoff. Erosion around the lake has exposed irrigation lines and impacted the utility structures around the lake, including the storm drain maintenance hole and irrigation vaults and piping.

Current Water Quality Improvements at HPL

Since water quality improvements can be implemented in a relatively short time frame and are independent of the downstream projects, an initial set of improvements is recommended to begin addressing water quality concerns at HPL. For long-term control of lake nutrients and algae, as well as to improve the park user experience, current water quality improvements are recommended to include floating wetland islands, an aeration system, and an alum injection system (see Figure ES-1). These improvements are anticipated to improve clarity and quality of HPL water through the following processes:

- **Floating Wetland Islands.** The floating wetland islands are expected to help control algae through competition for nutrients, enhanced settling of algal cells, and water column shading, and will assist with transformation and removal of nitrogen through denitrification.
- **Aeration.** Aeration is anticipated to improve water clarity through reduction in algal populations, and assist with nitrogen transformation from organic and ammonia forms by nitrification, and to enhance decomposition of organic sediments, thereby reducing internal loading from HPL sediments.
- **Chemical Feed System Retrofit.** Alum injection will reduce phosphorus concentrations, thereby reducing algal populations and enhance solids settling.
- **Recirculation.** The existing recirculation system will integrate all of these nutrient removal and algal reduction processes by maintaining a short hydraulic residence time and assisting with the transport and distribution of alum throughout the lake, and through and around the root mat suspended from the floating wetland island.



Figure ES-1. Current Water Quality Improvements
Hollenbeck Park Lake Rehabilitation and Stormwater Management

Future Long-Term Improvements

The future long-term rehabilitation of HPL is proposed to include the use of alternative sources of water to eliminate the need for potable water use in lake make-up water, the construction of shoreline constructed wetlands to remove nutrients from the alternative water supply sources, and dredging to remove lake sediment, and liner renovation of HPL (Figure ES-2). Park landscaping enhancements are

proposed to reduce site erosion. These improvements will position HPL to maintain good water quality and achieve long-term control of algae while conserving water supply. Future improvements are meant to function together with the current improvements to support the long-term health and aesthetics of HPL. Future improvements also include stormwater management recommendations for 6th Street Viaduct and Mission/Jesse area.

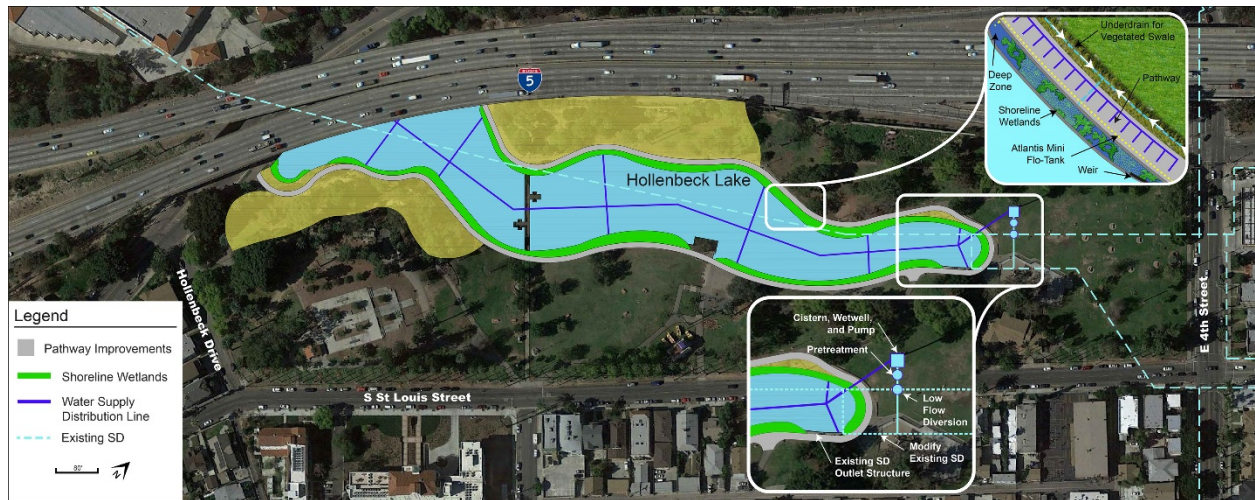

Figure ES-2. Future Park Improvements
Hollenbeck Park Lake Rehabilitation and Stormwater Management

- **Replacement of Potable Water.** Recycled water is recommended to replace potable water use for the Project. The use of recycled water for make-up will require additional treatment, which can be integrated into park shoreline and public use features.
- **Dry/Wet Weather Flow Diversion.** Dry weather flows and a portion of storm flows will be diverted and treated by the proposed shoreline wetlands at the lake. Diverted flows will be pretreated and pumped to the wetland system, or directly to the lake prior to the construction of the wetlands. A new submersible pump will be placed in the existing wet well that recirculates water from the lake. The recirculated water will be filtered and disinfected before distribution to the irrigation system.
- **Shoreline Wetlands.** Shoreline wetlands are included as a two-stage process to create an ecological habitat that will provide passive improvement of water quality through phosphorus uptake and assimilation, nitrogen transformation through denitrification, solids reduction through sedimentation and burial, algal control through shading and competition, and sequestration of metals as immobile and ecologically unavailable forms in wetland sediments. The new water supply (i.e., recycled water and low flow diversion) will be routed to the shoreline wetlands. In addition, stormwater and irrigation runoff from the park will be collected by a vegetated swale and routed to the shoreline wetlands. Water will be distributed through a gravel filter situated under a new pedestrian-friendly sidewalk, and discharged into a constructed shoreline wetland for final polishing before inflow to the lake (Figure ES-3).



Figure ES-3. Rendering of Shoreline Wetlands
Hollenbeck Park Lake Rehabilitation and Stormwater Management

- **Dewatering/Dredging.** Dredging of existing lake sediments will significantly improve water quality. Dredging can be performed using mechanical methods after the lake has been drained.
- **Lining.** A geosynthetic liner is recommended to eliminate seepage and significantly reduce the water demands at HPL. The geosynthetic liner has lower capital and installation costs compared with other materials.
- **Irrigation and Landscaping.** Water conservation methods can be applied to increase irrigation system water use efficiency. A key opportunity for Hollenbeck Park Lake is the use of water-wise landscape vegetation consisting of native, drought tolerant trees, shrubs, and mulch and smart irrigation controllers (with weather and soil moisture sensors).
- **Stormwater Management.** Rainwater harvesting and storage in underground cisterns is the primary stormwater management strategy proposed at the 6th Street Viaduct and Mission/Jesse area.

Preliminary Cost Estimate

Table ES-1 summarizes the total estimated conceptual project cost, including mark-ups, for Phase I and Phase II improvements. This cost estimate prepared is considered a Budget or Class 5 estimate as defined by the Association for the Advancement of Cost Engineering International. It is considered accurate to ± 50 percent, based on a 2 percent design deliverable. The total estimated project budget is \$33,852,586.

Table ES-1. Project Conceptual Cost Estimate

Hollenbeck Park Lake Rehabilitation and Stormwater Management

Current Improvements	
Floating Wetland Islands and Aeration System	\$522,000
Chemical Feed Retrofit	\$62,000
Concept Report	\$165,000
Grant Application	\$29,000
Optimization	\$89,000
Water Quality Monitoring	\$52,000
Project Management	\$31,000
TOTAL COST OF CURRENT IMPROVEMENTS	\$950,000
Future Improvements	
Removal, Transfer, and Storage of Floating Wetland Islands, Aeration System, and Fountain/Recirculation System	\$30,000
Lake Drawdown and Sediment Removal	\$4,000,000
Install Liner	\$2,179,813
Shoreline Wetland and Walkway Construction	\$7,289,920
Storm Drain Diversion to Wetlands/Lake	\$1,439,933
Reinstall and Refurbish of Floating Wetland Islands, Aeration System, and Fountain and Recirculation System	\$50,000
Park Grading and Landscaping	\$2,269,684
6th Street Viaduct Stormwater Management	\$1,765,959

Table ES-1. Project Conceptual Cost Estimate*Hollenbeck Park Lake Rehabilitation and Stormwater Management*

Mission/Jesse Stormwater Management	\$1,640,183
LADWP Recycled Water Connection	\$1,137,371
Operation and Maintenance Manuals	\$25,000
Utilities	\$1,600,000
Total Construction Cost	\$23,427,863
Mobilization/Demobilization (5 percent)	\$1,171,393
Maintenance of Vehicular/Ped Traffic (5 percent)	\$1,171,393
Survey During Construction (0.5 percent)	\$117,139
Direct Administrative Costs (11 percent)	\$2,160,000
Planning, Design, Engineering, Environmental (18 percent + \$25,000 Low Flow Study)	\$4,199,126
Construction Engineering (3 percent)	\$702,836
Post Construction Start-up, Testing, Optimization, and Establishment (3 percent)	\$702,836
Monitoring (Prop 1 Requirement)	\$100,000
Education and Outreach (Prop 1 Requirement)	\$100,000
TOTAL COST OF FUTURE IMPROVEMENTS	\$33,852,586

Preliminary Implementation Schedule

Table ES-2 presents the anticipated project schedule for design, permitting, and construction.

Table ES-2. Preliminary Implementation Schedule*Hollenbeck Park Lake Rehabilitation and Stormwater Management*

Task	Start Date	End Date
Install Current Improvements	July 2016	November 2016
Planning and Design of Future Improvements	July 2016	June 2018
Construction of Future Hollenbeck Park Improvements	October 2018	June 2020
Construction of Future 6th Street Viaduct Stormwater Management	January 2020	June 2020
Construction of Future Mission/Jesse Stormwater Management	January 2019	July 2019

Contents

Section	Page
Executive Summary	iii
Acronyms and Abbreviations	vii
1 Introduction	1-1
1.1 Project Objectives.....	1-1
1.2 Downstream Facility Integration	1-1
1.2.1 6th Street Viaduct Parklands	1-1
1.2.2 Mission Road/Jesse Street Projects.....	1-2
2 Existing Conditions	2-1
2.1 Recreation and Open Space.....	2-1
2.2 Soil and Groundwater	2-1
2.3 Hydrology and Storm Drain System.....	2-1
2.3.1 Tributary Area	2-1
2.3.2 Non-stormwater Flows	2-4
2.4 Sewer Infrastructure	2-4
2.5 Erosion/Pedestrian Accessibility.....	2-5
2.6 Water Balance Model	2-10
2.6.1 Inflows.....	2-10
2.6.2 Outflows.....	2-12
2.6.3 Hollenbeck Park Lake Water Balance Results.....	2-13
2.7 Water Quality.....	2-15
2.7.1 Previous Improvements.....	2-15
2.7.2 Current Improvements	2-16
3 Water Supply Alternatives Analysis	3-1
3.1 Water Demand.....	3-1
3.2 Regulatory Setting.....	3-4
3.2.1 Federal	3-4
3.2.2 State	3-5
3.2.3 Local	3-6
3.3 Alternative 1: Los Angeles River	3-7
3.3.1 Flow Analysis.....	3-7
3.3.2 Conceptual Design	3-8
3.3.3 Permitting	3-17
3.3.4 Cost	3-18
3.4 Alternative 2: LADWP Recycled Water	3-18
3.4.1 Flow Analysis.....	3-18
3.4.2 Conceptual Design	3-20
3.4.3 Permitting	3-21
3.4.4 Cost	3-22
3.5 Alternative 3: Sewer Mining	3-23
3.5.1 Flow Analysis.....	3-23
3.5.2 Conceptual Design	3-23
3.5.3 Permitting	3-27
3.5.4 Cost	3-28
3.6 Alternative 4: Non-stormwater and Stormwater Flow Diversion.....	3-29

3.6.1	Flow Analysis.....	3-29
3.6.2	Conceptual Design	3-29
3.6.3	Permitting	3-30
3.6.4	Costs.....	3-31
3.7	Alternatives Analysis Summary.....	3-31
3.7.1	Recommendation	3-32
4	Current Water Quality Improvements at HPL.....	4-1
4.1	Floating Wetland Islands.....	4-2
4.1.1	Background	4-2
4.1.2	Application	4-2
4.1.3	Cost	4-4
4.2	Aeration	4-4
4.2.1	Background	4-4
4.2.2	Application	4-4
4.2.3	Cost	4-5
4.3	Chemical Feed System Retrofit.....	4-6
4.3.1	Background	4-6
4.3.2	Application.....	4-7
4.3.3	Cost	4-11
5	Future Long-Term Improvements	5-1
5.1	Replacement of Potable Water	5-1
5.2	Dry/Wet Weather Flow Diversion	5-1
5.3	Shoreline Wetlands.....	5-1
5.3.1	Technology Background.....	5-1
5.3.2	Application	5-2
5.3.3	Cost	5-9
5.4	Dredging.....	5-9
5.4.1	Background	5-9
5.4.2	Application	5-9
5.4.3	Permitting	5-11
5.4.4	Cost	5-11
5.5	Lining.....	5-15
5.5.1	Background	5-15
5.5.2	Application	5-15
5.5.3	Cost	5-16
5.6	Irrigation and Landscaping at Hollenbeck Park	5-16
5.6.1	Considerations for Improved Irrigation Efficiency.....	5-16
5.6.2	Landscaping	5-17
5.6.3	Cost	5-17
5.7	Stormwater Management	5-21
5.7.1	Regulatory Background.....	5-21
5.7.2	Pretreatment	5-21
5.7.3	Storage and Pump.....	5-22
5.7.4	Processing	5-23
5.7.5	Cost	5-29
5.8	Pollutant Reduction in Watershed.....	5-29
6	Cost Estimate and Implementation Schedule	6-1
6.1	Basis of Estimate	6-1
6.2	Total Project Cost.....	6-3

6.3	Funding Opportunities.....	6-4
6.3.1	City of Los Angeles Proposition O.....	6-4
6.3.2	California Proposition 1.....	6-4
6.3.3	Clean Water State Revolving Fund.....	6-5
6.4	Implementation Schedule.....	6-5
7	References.....	7-1

Tables

Table ES-1.	Project Conceptual Cost Estimate
Table ES-2.	Preliminary Implementation Schedule
Table 2-1.	2010-2015 Average Monthly Modeled Evapotranspiration and Seepage Rates
Table 3-1.	Seasonal Water Demands
Table 3-2.	Los Angeles River Average Flows at Arroyo Seco Station F57C from October 2012 to January 2016
Table 3-3.	Monthly Flow Demand at Los Angeles River
Table 3-4.	Preliminary Summary of Environmental Permits/Approvals for Los Angeles River Source Alternative
Table 3-5.	Preliminary Summary of Environmental Permits/Approvals for LADWP Recycled Water Source Alternative
Table 3-6.	Preliminary Summary of Environmental Permits/Approvals for Sewer Mining Source Alternative
Table 3-7.	Preliminary Summary of Environmental Permits/Approvals for Dry/Wet Weather Flow Diversion Alternative
Table 3-8.	Recycled Water Demand
Table 5-1.	Dredging Options
Table 5-2.	Pollutant Loading Reductions
Table 6-1.	General Contractor Markups
Table 6-2.	Project Cost Estimate

Figures

Figure ES-1.	Current Water Quality Improvements
Figure ES-2.	Future Park Improvements
Figure ES-3.	Rendering of Shoreline Wetlands
Figure 1-1.	Vicinity Map
Figure 2-1.	Hollenbeck Park Tributary Areas
Figure 2-2.	Northern Outlet/Inlet Structure
Figure 2-3.	Southern Outlet Structure
Figure 2-4.	Storm Drain Outfall to Lake
Figure 2-5.	Storm Drain Outfalls from I-5 Freeway
Figure 2-6.	HPL Sewer System
Figure 2-7.	Locations of Below Photos Taken at Hollenbeck Park on March 1, 2016
Figure 2-7-A.	Erosion Between Bridge Decks Exposing Pipe
Figure 2-7-B.	Erosion Rills on Abutment and Lake Edge
Figure 2-7-C.	Lakeside Erosion Exposing Utility Vault
Figure 2-7-D.	Lakeside Erosion
Figure 2-7-E.	Lakeside Erosion Exposing Irrigation Lines
Figure 2-7-F.	Lakeside Erosion at Storm Drain Manhole
Figure 2-7-G.	Lakeside Erosion Exposing Irrigation Lines

Figure 2-7-H. Lakeside Erosion Undermining Pavement
 Figure 2-7-I. Lakeside Erosion Undermining Pavement and Tree
 Figure 2-7-J. Lakeside Erosion
 Figure 2-7-K. Lakeside Erosion Exposing Irrigation Lines
 Figure 2-7-L. Lakeside Erosion
 Figure 2-7-M. Hillside Erosion Exposing Irrigation Lines
 Figure 2-7-N. Hillside Erosion Exposing Irrigation Lines
 Figure 2-7-O. Lakeside Erosion
 Figure 2-7-P. Lakeside Erosion
 Figure 2-8. Monthly Average Stormwater Inflows to Lake 2010-2015
 Figure 2-9. Monthly Average Modeled vs. Measured Potable Water Deliveries to Lake 2010-2015
 Figure 2-10. 2010-2015 Average Monthly HPL Outflows
 Figure 2-11. HPL Daily Water Levels and Precipitation
 Figure 3-1. Average Monthly Water Demands
 Figure 3-2. Los Angeles River Intake Structure Conceptual Design, Water Supply Alternative: Los Angeles River
 Figure 3-3. Conceptual Conveyance Alignment, Water Supply Alternative: Los Angeles River
 Figure 3-4. Conceptual Alignment for Freeway Crossing and Existing Easements
 Figure 3-5. Irrigation Pump at Existing Chemical Feed System, Water Supply Alternative: Los Angeles River
 Figure 3-6. Process Flow Diagram, Water Supply Alternative: Los Angeles River
 Figure 3-7. Proposed DTWRP and 6th Street Connection, Water Supply Source: LADWP Recycled Water
 Figure 3-8. Conceptual Conveyance Alignment, Water Supply Alternative: LADWP Recycled Water
 Figure 3-9. Process Flow Diagram, Water Supply Alternative: LADWP Recycled Water
 Figure 3-10. Simplified Process Schematic of MBR System
 Figure 3-11. Example of a Packaged (Containerized) MBR System
 Figure 3-12. Conceptual Conveyance Alignment, Water Supply Alternative: Sewer Mining
 Figure 3-13. Process Flow Diagram, Water Supply Alternative: Sewer Mining
 Figure 3-14. Conceptual Conveyance Alignment, Water Supply Alternative: HPL Overflows
 Figure 3-15. Process Flow Diagram of Proposed Water Supply at HPL
 Figure 4-1. Typical Floating Wetland Island Configuration
 Figure 4-2. Typical Diffuser
 Figure 4-3. Process Flow Diagram for Chemical Feed System Retrofit
 Figure 4-4. Chemical Feed System Equipment Layout
 Figure 4-5. Location of Current Water Quality Improvements
 Figure 5-1. Cross-section of Shoreline Wetland
 Figure 5-2. Cross-section of Shoreline Wetland
 Figure 5-3. Rendering of Shoreline Wetlands
 Figure 5-4. Water Quality Improvements at HPL
 Figure 5-5. Hollenbeck Park Landscaping Plan
 Figure 5-6. Terraced Water-wise Landscaping (Before)
 Figure 5-7. Terraced Water-wise Landscaping (Rendering)
 Figure 5-8. Typical Hydrodynamic Separator
 Figure 5-9. Typical StormCapture System
 Figure 5-10. Typical Water Treatment Processing Skid
 Figure 5-11. Stormwater Management System at 6th Street Viaduct Parklands
 Figure 5-12. Stormwater Management System at Mission/Jesse
 Figure 6-1. Implementation Schedule

Acronyms and Abbreviations

µg Al/L	micrograms aluminum per liter
AFY	acre-feet per year
alum	aluminum sulfate
ATF	Air Treatment Facility
CCR	<i>California Code of Regulations</i>
CDFW	California Department of Fish and Wildlife
CDPH	California Department of Public Health
CEQA	California Environmental Quality Act
cfs	cubic feet per second
CH2M	CH2M HILL Engineers, Inc.
CIMIS	California Irrigation Management Information System
CIP	clean in place
CWA	Clean Water Act
DO	dissolved oxygen
DTWRP	Downtown Water Recycling Project
EA	Environmental Assessment
FONSI	Finding of No Significant Impact
FWI	floating wetland island
gal/month	gallon per month
GCL	geosynthetic clay liner
GLAC IRWM	Greater Los Angeles County Integrated Regional Water Management Plan
GLAC IRWMP	2014 Greater Los Angeles County Region Integrated Regional Water Management Plan
hp	horsepower
HPL	Hollenbeck Park Lake
I	Interstate
IS	Initial Study
LA Parks	Los Angeles Department of Recreation and Parks
LACDPH	Los Angeles County Department of Public Health
LACDPW	Los Angeles County Department of Public Works
LACFCD	Los Angeles County Flood Control District
LADPW	City of Los Angeles Department of Public Works
LADWP	City of Los Angeles Department of Water and Power

ACRONYMS AND ABBREVIATIONS

LASAN	City of Los Angeles Bureau of Sanitation
MBR	membrane bioreactor
mg/L	milligrams per liter
mL	milliliter
MND	Mitigated Negative Declaration
ND	Negative Declaration
NEPA	National Environmental Policy Act
NOI	Notice of Intent
NPDES	National Pollutant Discharge Elimination System
NPT	national pipe taper
NTU	nephelometric turbidity unit
O&M	operation and maintenance
Petition for Change	Petition for Change for Owners of Waste Water Treatment Plants
PVC	polyvinyl chloride
RBF	Robert Bein, William Frost and Associates
RCP	reinforced concrete pipe
RWQCB	Regional Water Quality Control Board
SAA	Streambed Alteration Agreement
SLIDE	Simplified Landscape Irrigation Demand Estimation
SPAW	Soil-Plant-Atmosphere-Water
SWRCB	State Water Resources Control Board
ULAR EWMP	Upper Los Angeles River Enhanced Watershed Management Plan
USACE	U.S. Army Corps of Engineers
UV	ultraviolet
VCP	vitriified clay pipe
WDR	waste discharge requirement

Introduction

Hollenbeck Park is an urban park in Boyle Heights within Los Angeles Council District 14 that provides aesthetic and recreational public uses for the community. The park is centered on Hollenbeck Park Lake (HPL), a 4.3-acre man-made urban water body that serves as an attractive water feature for public enjoyment. HPL is highly valued by the community as a recreational asset where green space is rare.

The purpose of this Conceptual Design Report for the Hollenbeck Park Lake Rehabilitation and Stormwater Management Project (the Project) is to evaluate alternatives for a holistic stormwater approach that integrates improvements at HPL with the proposed Mission/Jesse Greenway through modifications to the 6th Street Viaduct currently in construction, and the nearby pocket park at the Mission Road Air Treatment Facility (ATF). A major component of a sustainable stormwater solution will be replacing potable water with an alternative source to meet the water needs within the watershed.

The City of Los Angeles Bureau of Sanitation (LASAN) is in the process of implementing water quality improvements at HPL and seeks to replace the potable water deliveries at HPL and downstream facilities with an alternative water source. The concept report will include the short-term solutions for improving water quality at HPL, and provide long-term recommendations on a long-term project to apply for State Proposition One grant funding. This report describes project considerations, recommendations, and implementation.

1.1 Project Objectives

The proposed project concept is intended to achieve the following objectives:

- Replace 74.1 acre-feet per year (24.1 million gallons) of potable water supply at HPL and downstream facilities with an alternative, sustainable water source
- Improve water quality and control algae at HPL
- Restore HPL's appearance and provide a long-term solution to erosion around the lake's edge
- Provide treatment/management of dry/wet weather flow in the watershed
- Harvest stormwater and reuse for irrigation and other water demands

1.2 Downstream Facility Integration

The location of Hollenbeck Park presents an opportunity to integrate future water use at the park with new and proposed nearby downstream facilities located at the 6th Street Viaduct Replacement Project and the intersection of Mission Road and Jesse Street. Project alternatives and recommendations will also consider water demands at these locations. For planning and cost purposes of this Concept Report, only the stormwater management and delivery of an alternative water source to these downstream facilities is considered. Figure 1-1 shows the vicinity of these project locations.

1.2.1 6th Street Viaduct Parklands

Replacement of the existing 6th Street Viaduct is one of the largest projects in the history of the City of Los Angeles and is located southwest of Hollenbeck Park between Mateo Street and Boyle Avenue, along 6th Street/Whittier Boulevard. Removal of the existing iconic bridge began in 2015 and the new viaduct is scheduled to be complete in 2019. Parks, open space, and community amenities will be incorporated below the bridge introducing a new irrigation demand. Approximately 7 acres under the viaduct, east of the Los Angeles River, will be transformed into recreational parklands. Conceptual

landscaping plans indicate approximately 60 percent of this land will require irrigation. Underground storage of stormwater for irrigation reuse is proposed along the southern edge of the bridge and will be sized to meet the water quality volume of the commencing bridge project.

1.2.2 Mission Road/Jesse Street Projects

There are four projects located south of the 6th Street Viaduct near the intersection of Mission Road and Jesse Street, including an existing ATF and pocket park, a future roundabout providing stormwater storage, and future wetlands. Each project has facility or irrigation water demands.

The Mission/Jesse ATF is located 0.5 miles west of Hollenbeck Park and was completed in 2015. The ATF treats foul air resulting from the transition of the North Outfall Sewer to the East Central Interceptor Sewer. The facility's bio trickling filtration system consumes approximately 11.8 acre-feet per year (AFY) of potable water. In association with the ATF construction, the triangular parcel north of the ATF was converted into a small pocket park.

Cycle 1 Active Transportation Plan grant funding has been awarded for bicycle and pedestrian improvements along portions of Mission Road and Myers Street, 500 feet from the Jesse Street intersection. The intersection will be converted into a roundabout that will also provide underground storage of stormwater runoff to supplement nearby demands. The proposed Dragonfly Wetlands project will be located within the remaining parcel southwest of the intersection.

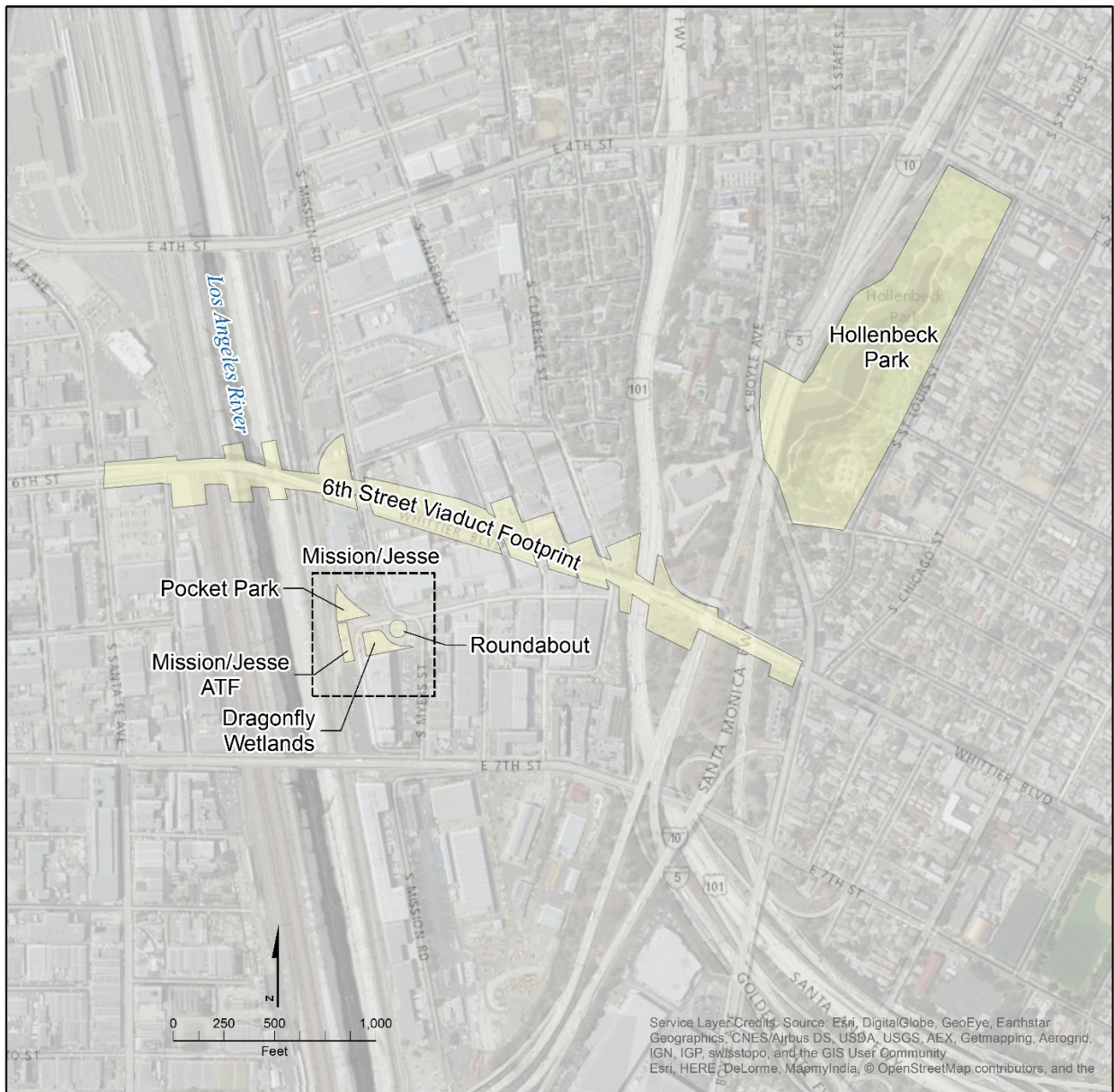

Figure 1-1. Vicinity Map
Hollenbeck Park Lake Rehabilitation and Stormwater Management

Existing Conditions

HPL was created in 1892 and has been a central feature of Hollenbeck Park and the Boyle Heights community for over a century. Illustrations and photographs from 1901 clearly show HPL in a tranquil park setting with lakeside trails, benches, and overlooks. HPL was always intended to function as an aesthetic amenity to the community. The park is located at 415 South Saint Louis Street, within the Boyle Heights neighborhood of Los Angeles and tributary to the Los Angeles River.

2.1 Recreation and Open Space

Hollenbeck Park is used by the community for walking, exercising, picnicking, and also has an auditorium, barbecue pits, basketball court, playground, picnic tables, and community room. The park has a recreational lake with a walking path around HPL. The lake can be used for non-motorized boats and is regularly restocked for fishing.

2.2 Soil and Groundwater

The *Los Angeles County Flood Control Hydrology Manual* identifies Ramona Loam as the underlying soil in the area, which is a well-draining soil (LACDPW, 2006). Hollenbeck Park is located above the Central Basin groundwater basin. The Los Angeles County Department of Public Works (LACDPW) online well database indicates the depth to groundwater exceeds 200 feet. The nearest well, located 1.4 miles south of Hollenbeck Park, reported a 243.90-foot depth to groundwater measured on February 18, 2016 (LACDPW, 2016).

2.3 Hydrology and Storm Drain System

2.3.1 Tributary Area

There are three tributaries to HPL, as shown on Figure 2-1, that enter HPL through the following means:

- **Park Overland Flows** – Stormwater runoff from the park enters HPL via overland flows. The park is approximately 20 acres with turf as a majority of the open ground cover. Based on the impervious data provided by the *Los Angeles County Flood Control Hydrology Manual*, the park is assumed to be 10 percent impervious (LACDPW, 2006).
- **LACFCD High-flow Outlet Structure** – The original storm drain system to HPL was a 7-foot wooden culvert constructed in 1901 that delivered flows to the northern tip of HPL on East 4th Street. The wood culvert was later replaced by two parallel 3-foot cement pipes. In 1911, the northern part of HPL was filled and a 39-inch reinforced concrete pipe (RCP) was constructed under the lake with a special junction structure connecting to the existing cement pipes. This junction structure directed low-flows from the existing system underneath the lake while allowing any overflow to discharge directly to the lake.

In 1959, a new Los Angeles County Flood Control District (LACFCD) storm drain system was connected to HPL and storm drain system. The 81-inch RCP that enters Hollenbeck Park at the corner of South Saint Louis Street and East 4th Street connects to a 60-foot inlet/outlet structure, as shown on Figure 2-2. This structure releases high-flows to the lake and directs low-flows to bypass under the park. The structure has an 18-inch low-flow diversion that connects to the existing 39-inch RCP under the lake. The same structure also acts as an outlet when lake levels rise. Therefore, the outlet structure discharges water to the lake only in high-flow conditions but allows any low-flows to

bypass. The entire tributary area to this storm drain system is estimated to be 430 acres, of which 156 acres are tributary to the LACFCD storm drain system as shown on Figure 2-1.

The existing outlet at the southern end of the lake as shown on Figure 2-3 was also constructed in 1959 and connects a LACFCD 96-inch RCP, which eventually discharges to the Los Angeles River. Older lake outlets are shown on previous as-built plans but are assumed to be no longer in use.

- Direct Storm Drain Connection – Four inlets collect stormwater from the residential area southeast of HPL. These inlets discharge directly to the lake via a 6-inch pipe near the gazebo structure as shown on Figure 2-4. As-built information was not available for this connection. This area is estimated to be 15.3 acres. The residential area is assumed to be 59 percent impervious.
- Interstate (I) 5 Freeway – A portion of the northbound I-5 freeway bridge that crosses over the southern end of the park drains directly from the bridge deck into the lake by a series of small culvert openings as shown on Figure 2-5. The tributary area from the freeway is estimated to be only 1.8 acres, which is entirely impervious.

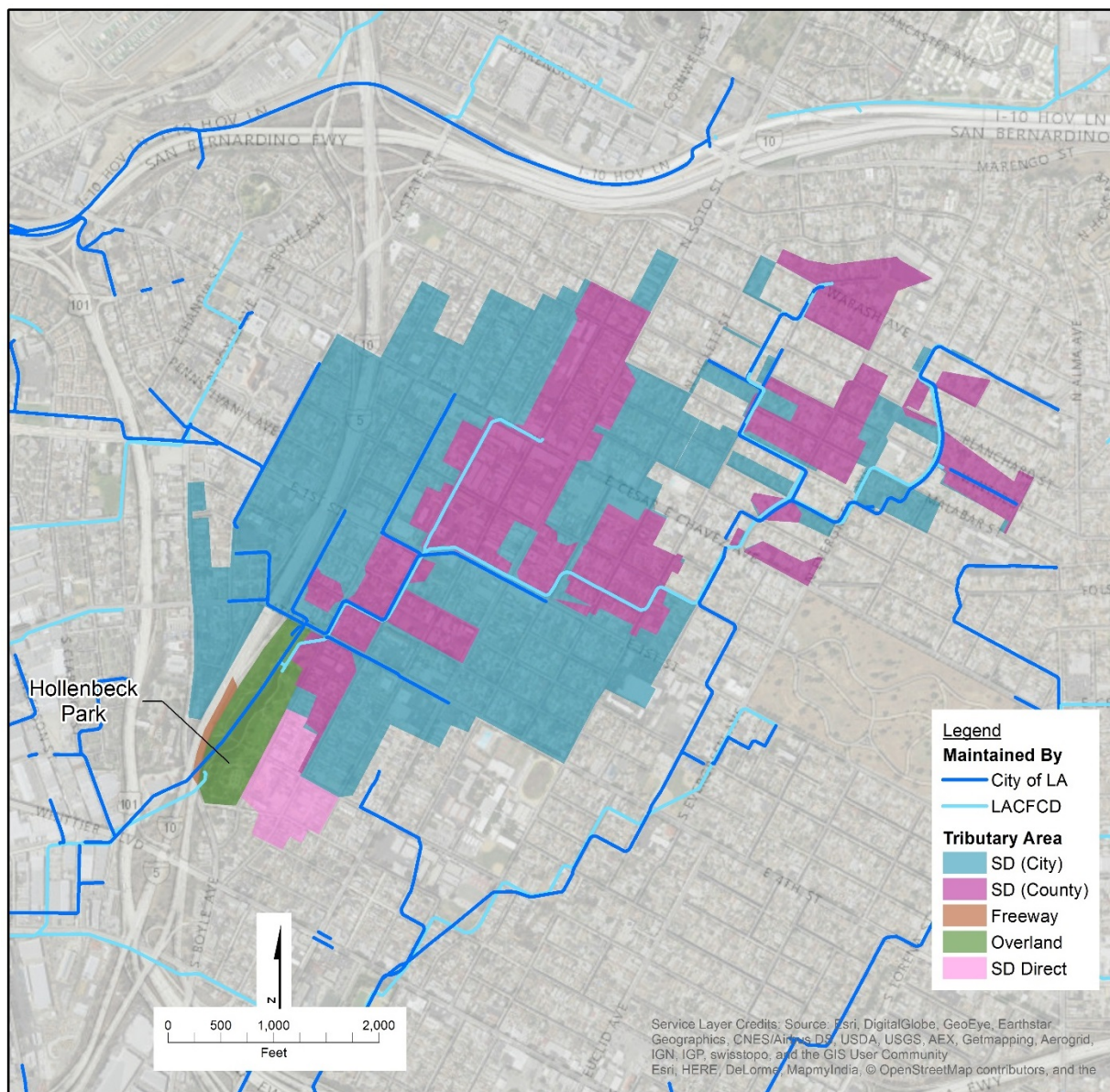

Figure 2-1. Hollenbeck Park Tributary Areas
Hollenbeck Park Lake Rehabilitation and Stormwater Management



Figure 2-2. Northern Outlet/Inlet Structure
Hollenbeck Park Lake Rehabilitation and Stormwater Management

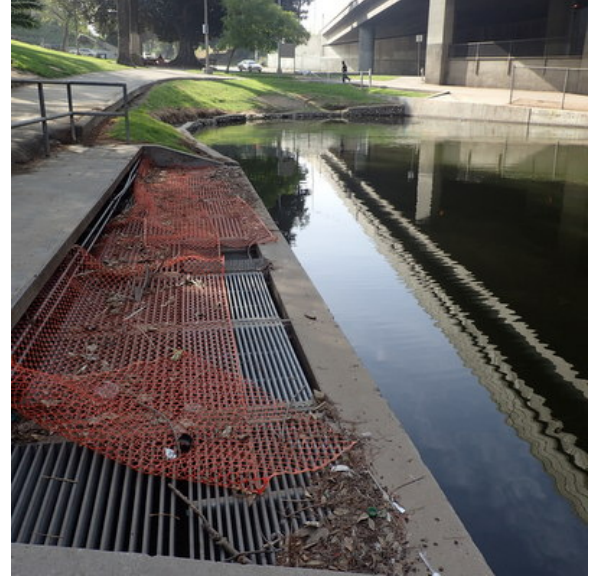

Figure 2-3. Southern Outlet Structure
Hollenbeck Park Lake Rehabilitation and Stormwater Management



Figure 2-4. Storm Drain Outfall to Lake
Hollenbeck Park Lake Rehabilitation and Stormwater Management



Figure 2-5. Storm Drain Outfalls from I-5 Freeway
Hollenbeck Park Lake Rehabilitation and Stormwater Management

2.3.2 Non-stormwater Flows

Given the 430-acre tributary area, the system likely has non-stormwater flows that currently bypass HPL. To estimate the flows bypassing HPL, flow rates from previous reports and projects were evaluated. The 2015 Upper Los Angeles River Enhanced Watershed Management Program (ULAR EWMP) estimates non-stormwater flows by population and outdoor water use (CH2M et al., 2016). The EWMP finds that the median outdoor water use is 68 gallons per capita per day assuming 2.97 persons per household (reference). Based on 2014 parcel data, there are approximately 1,600 households within the tributary area resulting in 4,750 persons and a non-stormwater flow rate of 362 AFY. This value represents the expected median outdoor use, and not an actual dry weather flow. The actual dry weather flow is assumed to be less than the outdoor use, as only a portion of the outdoor water use is expected to run off the site.

The 2009 Downtown Los Angeles Storm Drain Low-Flow Diversion Project Work Plan is designed to treat runoff from approximately 440 acres with an estimated average flow of 3 to 5 cubic feet per second (cfs) (LADPW, 2009). Based on this area to flow rate ratio, the low-flow is estimated to be 3,538 AFY for the 430-acre tributary area.

The 2008 *South Los Angeles Wetland Park Preliminary Design Report* originally estimated a base flow of 80,000 gallons per day, but flow measurements concluded the actual base flow was 14,000 gallons per day for a 525-acre tributary area (Psomas, 2008). Based on this flow rate to area ratio, the low-flow is estimated to be 13 AFY for the 430-acre tributary area.

As drought conditions persist and water conservation measures increase in effectiveness, dry weather flows are decreasing in the watershed. While the values for estimating non-stormwater flows are wide in range, it is likely that the Project's dry weather flow will be closer to the low end of the spectrum. The Mayor's Executive Order No. 5, issued October 14, 2014, required the City of Los Angeles to achieve significant reductions in irrigation use of potable water. Also, many of the EWMP implementation measures will reduce future dry weather flows. Therefore, a 13 AFY non-stormwater flow estimate is assumed for the storm drain at Hollenbeck Park. A dry weather flow study is recommended to confirm the volume of dry weather flow from the watershed.

2.4 Sewer Infrastructure

Aside from the storm drain system, there is also a sewer system below HPL, as shown on Figure 2-6. An 18-inch vitrified clay pipe (VCP) extends below the length of the lake with 8- and 15-inch VCP connections from the surrounding neighborhood. Navigate LA provides sewer capacities for each of the storm drain lines. The 18-inch sewer has a capacity of approximately 7 cfs (5,071 AFY), the 15-inch sewer has a capacity of approximately 5 cfs (3,622 AFY), and the 8-inch sewers have a capacity of approximately 2 cfs (1,448 AFY) (LADPW, 2016).

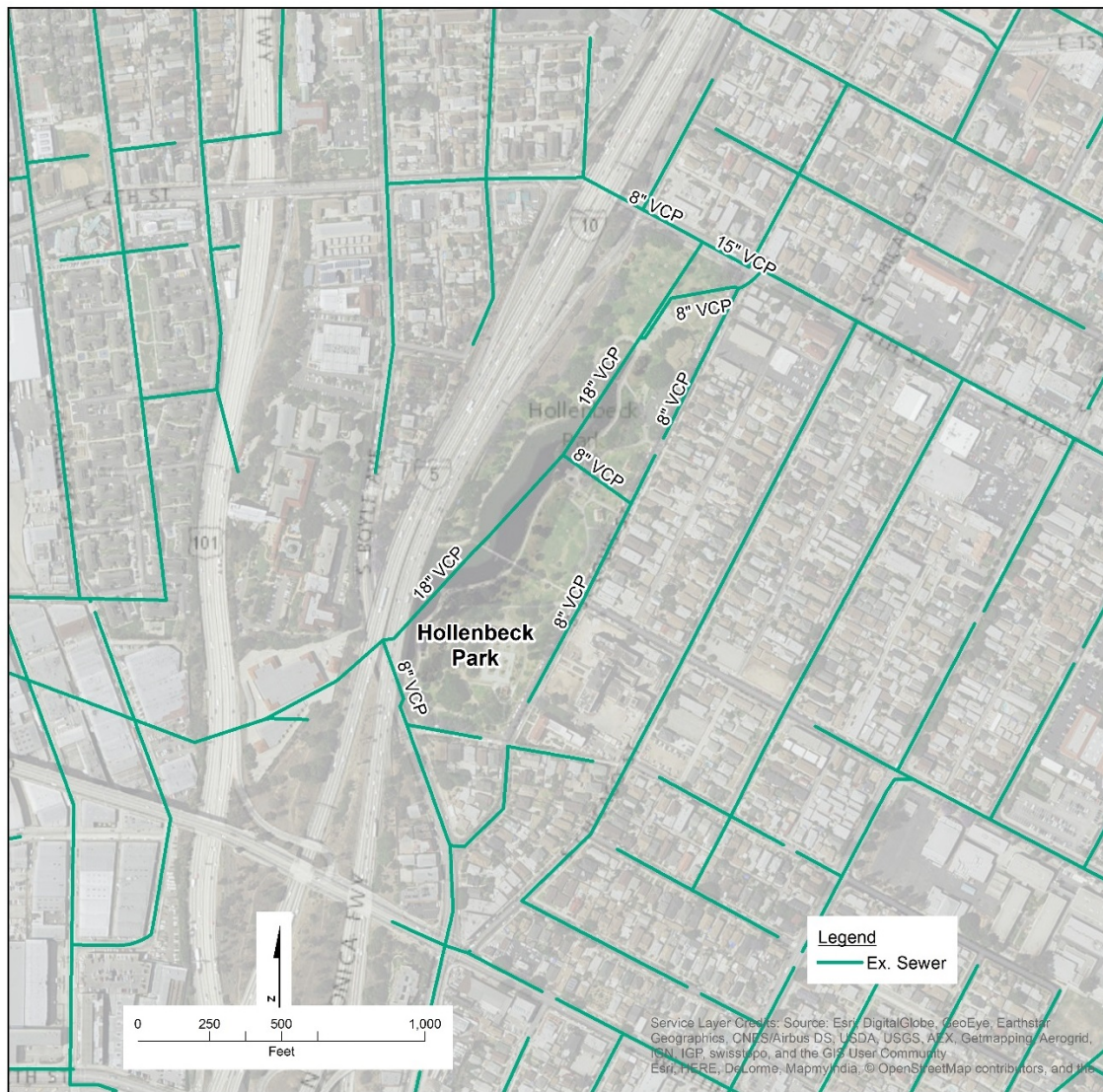

Figure 2-6. HPL Sewer System
Hollenbeck Park Lake Rehabilitation and Stormwater Management

2.5 Erosion/Pedestrian Accessibility

There is extensive erosion around the perimeter of HPL. Photos taken during the March 1, 2015 site visit shown on Figures 2-7-A through 2-7-P illustrate the erosion around the lake. Erosion rills were observed under the I-5 overpass along the lake's edge as well as the abutment slope as shown on Figures 2-7-A and 2-7-B. Erosion was observed on all sides of the lake, and was most notable along the vegetated areas between the lake edge and existing pedestrian walkway. Erosion has also begun to undermine the existing pavement and trees (Figure 2-7-H). Less significant erosion was observed on the slope leading up to the plaza area located near the corner of Hollenbeck Drive and Saint Louis Street, see Figures 2-7-M and 2-7-N. Aside from the lake's edge, most turf vegetated areas do not show signs of erosion.

The erosion is likely a result of the steep slopes around the lake, which produce erosive velocities for stormwater and irrigation runoff. Erosion around the lake has exposed irrigation lines and impacted the utility structures around the lake, including the storm drain maintenance hole and irrigation vaults and piping. The erosion has also compromised visitor safety by creating falling and tripping hazards near the edge of the pedestrian path.

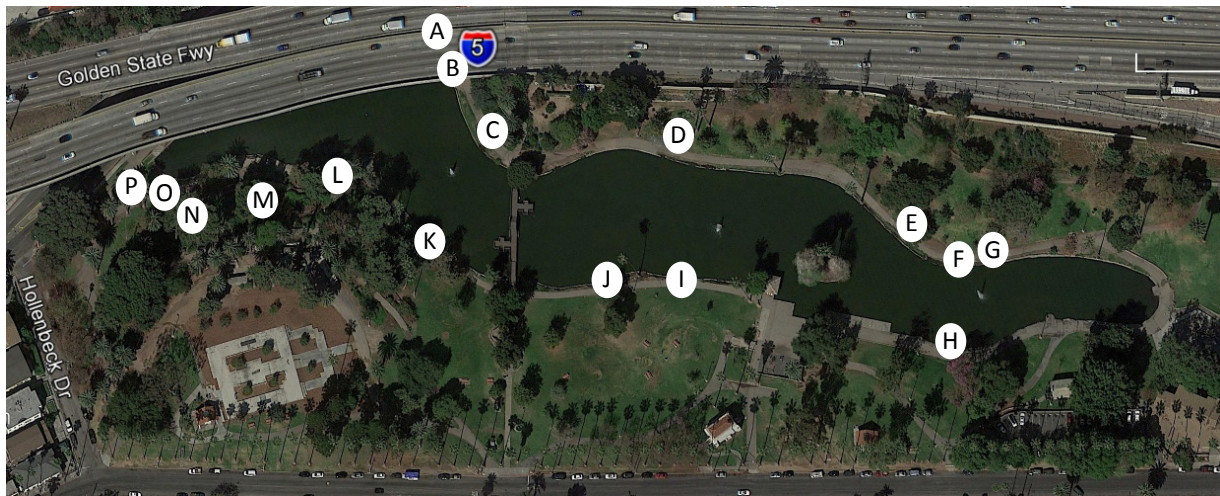

Figure 2-7. Locations of Below Photos Taken at Hollenbeck Park on March 1, 2016
Hollenbeck Park Lake Rehabilitation and Stormwater Management
Aerial Image ©Google Earth, 2016, Annotation by CH2M, 2016



Figure 2-7-A. Erosion Between Bridge Decks Exposing Pipe
Hollenbeck Park Lake Rehabilitation and Stormwater Management



Figure 2-7-B. Erosion Rills on Abutment and Lake Edge
Hollenbeck Park Lake Rehabilitation and Stormwater Management



Figure 2-7-C. Lakeside Erosion Exposing Utility Vault
Hollenbeck Park Lake Rehabilitation and Stormwater Management



Figure 2-7-D. Lakeside Erosion
Hollenbeck Park Lake Rehabilitation and Stormwater Management



Figure 2-7-E. Lakeside Erosion Exposing Irrigation Lines
Hollenbeck Park Lake Rehabilitation and Stormwater Management



Figure 2-7-F. Lakeside Erosion at Storm Drain Manhole
Hollenbeck Park Lake Rehabilitation and Stormwater Management



Figure 2-7-G. Lakeside Erosion Exposing Irrigation Lines
Hollenbeck Park Lake Rehabilitation and Stormwater Management



Figure 2-7-H. Lakeside Erosion Undermining Pavement
Hollenbeck Park Lake Rehabilitation and Stormwater Management



Figure 2-7-I. Lakeside Erosion Undermining Pavement and Tree
Hollenbeck Park Lake Rehabilitation and Stormwater Management



Figure 2-7-J. Lakeside Erosion
Hollenbeck Park Lake Rehabilitation and Stormwater Management



Figure 2-7-K. Lakeside Erosion Exposing Irrigation Lines
Hollenbeck Park Lake Rehabilitation and Stormwater Management

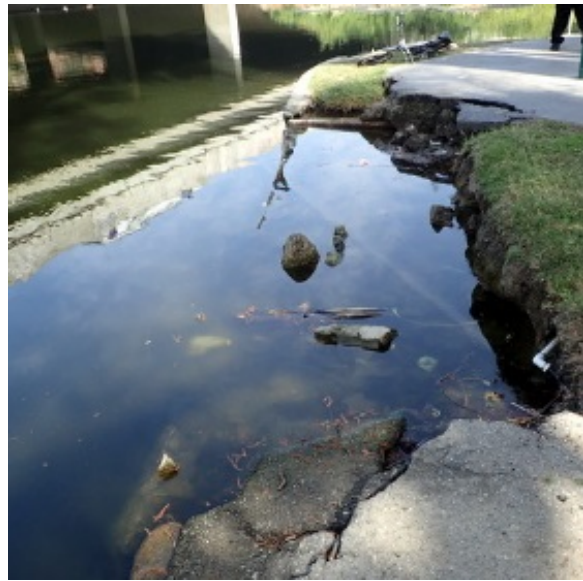

Figure 2-7-L. Lakeside Erosion Exposing Irrigation Lines
Hollenbeck Park Lake Rehabilitation and Stormwater Management



Figure 2-7-M. Hillside Erosion Exposing Irrigation Lines
Hollenbeck Park Lake Rehabilitation and Stormwater Management



Figure 2-7-N. Hillside Erosion Exposing Irrigation Lines
Hollenbeck Park Lake Rehabilitation and Stormwater Management



Figure 2-7-O. Lakeside Erosion
Hollenbeck Park Lake Rehabilitation and Stormwater Management



Figure 2-7-P. Lakeside Erosion
Hollenbeck Park Lake Rehabilitation and Stormwater Management

2.6 Water Balance Model

The Soil-Plant-Atmosphere-Water (SPAW) computer program model was used to estimate the daily water balance of HPL for a period of record from January 2010 through December 2015. The SPAW model was developed by the United States Department of Agriculture, Agricultural Research Service and Washington State University to simulate the daily water budget of an inundated depression or constructed impoundment (Saxton and Willey, 2011). Although developed for agricultural purposes, the model functions as a versatile all-purpose water balance assessment tool and can be applied to a wide range of water bodies. For HPL, available data was used to create a model of the lake system, which was calibrated to the average monthly record of metered potable water deliveries to the lake provided by the Los Angeles Department of Recreation and Parks (LA Parks). An average monthly value was calculated for any input data that was collected on a daily basis, such as precipitation. The water balance model's inflows and outflows inputs and the results are discussed below.

2.6.1 Inflows

2.6.1.1 Potable Water Supply to Lake

A record of potable water deliveries at HPL was provided from June 2014 through February 2016 for the meters throughout the park. A monthly delivery average was applied for years where delivery information was not available. As indicated by maintenance personnel, potable water is used to fill the lake when lake levels drop 6 inches below the overflow weir and is left to fill overnight. This happens about once per month. Based on water records it is estimated the lake potable water deliveries range from 227,000 gallons per month (gal/month) in December to 1,764,000 gal/month in August. The total average annual water supply to the lake is approximately 35.8 AFY.

2.6.1.2 Irrigation

HPL is likely to receive some flows from irrigation runoff. However, flows are considered minor in comparison to overall lake deliveries and were not incorporated into the water balance model.

2.6.1.3 Precipitation

Daily precipitation data from 2010 through 2015 was obtained from the Western Regional Climate Center (WRCC) for the University of Southern California rain gauge (45115) located approximately 4 miles southeast of Hollenbeck Park (WRCC, 2016).

2.6.1.4 Storm Drain Inflow

Stormwater runoff was calculated from three different sources including the LACFCD storm drain system, the direct storm drain connection, and the I-5 Freeway based on watershed characteristics and precipitation records. Soil in this area was assumed to be well draining Class B soils. Storm runoff entering HPL from the LACFCD high-flow outlet structure was calculated based off the 156-acre drainage area and the assumption that HPL received only a portion of the stormwater runoff from LACFCD, when rainfall events were greater than one inch. Since the majority of this drainage area is impervious, a runoff curve number of 98 was used in the model to calculate the anticipated storm drain flow to HPL. Stormwater runoff entering HPL from the direct storm drain connection was based off a 15.3-acre 59 percent impervious watershed and a weighted runoff curve number of 91 was used in the model. Interstate 5 Freeway runoff was calculated based off of a 1.8-acre entirely impervious watershed and a runoff curve number of 98 was used in the model to calculate the anticipated storm drain flow to HPL. Figure 2-8 shows the monthly lake inflows ranging from 0 to 4.9 million gallons, which totals 42 AFY.

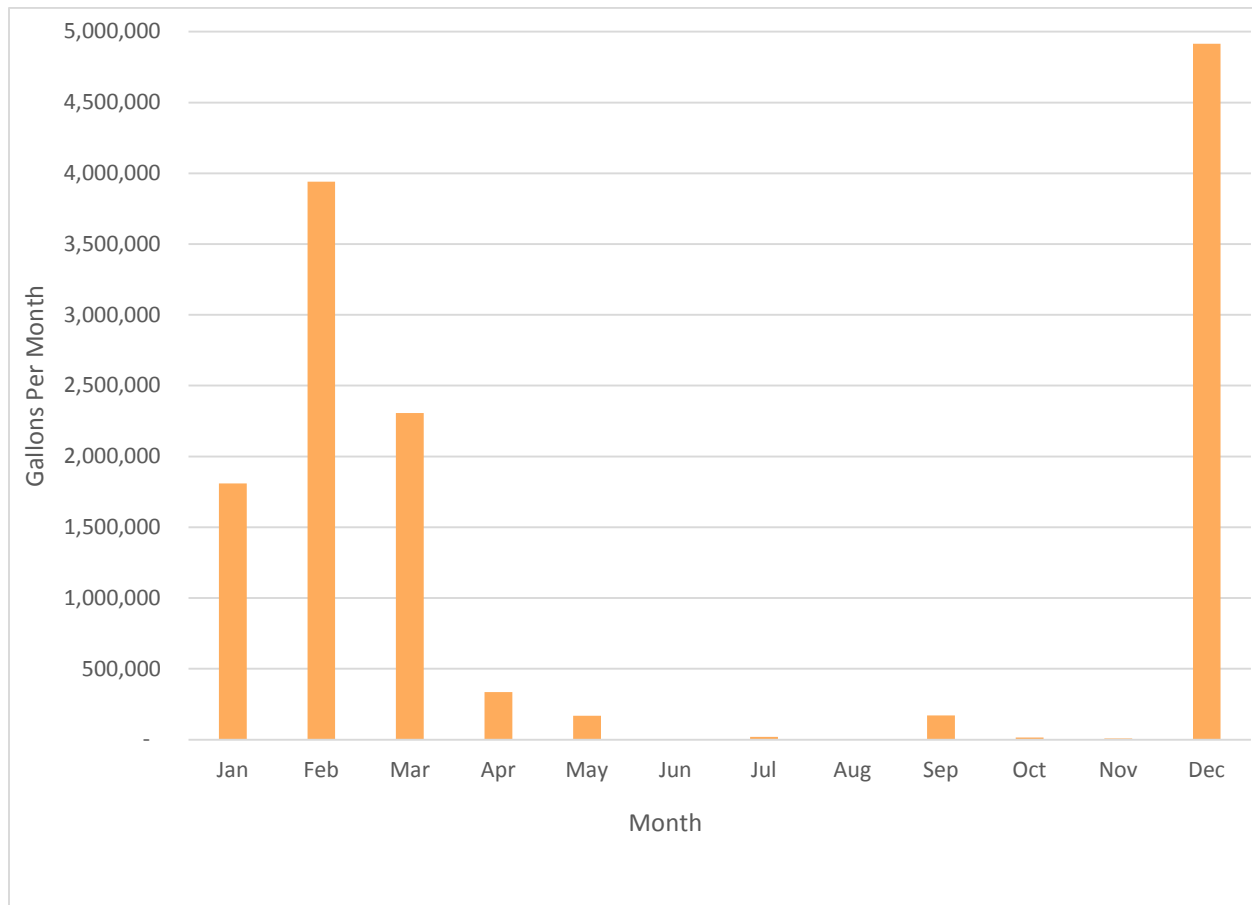

Figure 2-8. Monthly Average Stormwater Inflows to Lake 2010-2015
Hollenbeck Park Lake Rehabilitation and Stormwater Management

2.6.2 Outflows

2.6.2.1 Outflow Calculation

Two LACFCD overflow structures are located at the north and south ends of HPL. The model used the rectangular weir equation of $Q=CLH^{3/2}$, with a C value of 3.0 for broad-crested weirs, to estimate the outflow from HPL that occurs at the overflow structures.

2.6.2.2 Evapotranspiration

Evapotranspiration rates were estimated based on the California Irrigation Management Information System (CIMIS) Reference Evapotranspiration chart (CIMIS, 1999). Hollenbeck Park resides within Zone 6, which has an evapotranspiration rate ranging from 1.86 inches per month in December and January to 6.51 inches per month in July.

2.6.2.3 Model Calibration and Seepage

Using the input and output parameters described previously, the SPAW model was calibrated by comparing average monthly modeled potable water deliveries with average monthly metered potable water deliveries to HPL and adjusting wetland seepage. Average seepage rates of 0.3 inches per day during the dry summer season and 0.15 inches per day during the wet winter seasons were calibrated by trial adjustment to minimize the difference between average monthly modeled and metered potable water deliveries. A constant seepage rate for the summer season and for the winter season were chosen as simplifying assumptions for this planning-level modeling. Figure 2-9 presents the monthly average potable water deliveries of the calibrated SPAW model and the measured potable water delivery data. Modeled potable water flows track the measured potable water supplied to HPL reasonably well and follow the seasonality of the summer and winter conditions. For example, both the modeled and measured potable water flows supplied to HPL increase during the dry summer season and decrease during the wet winter season as expected.

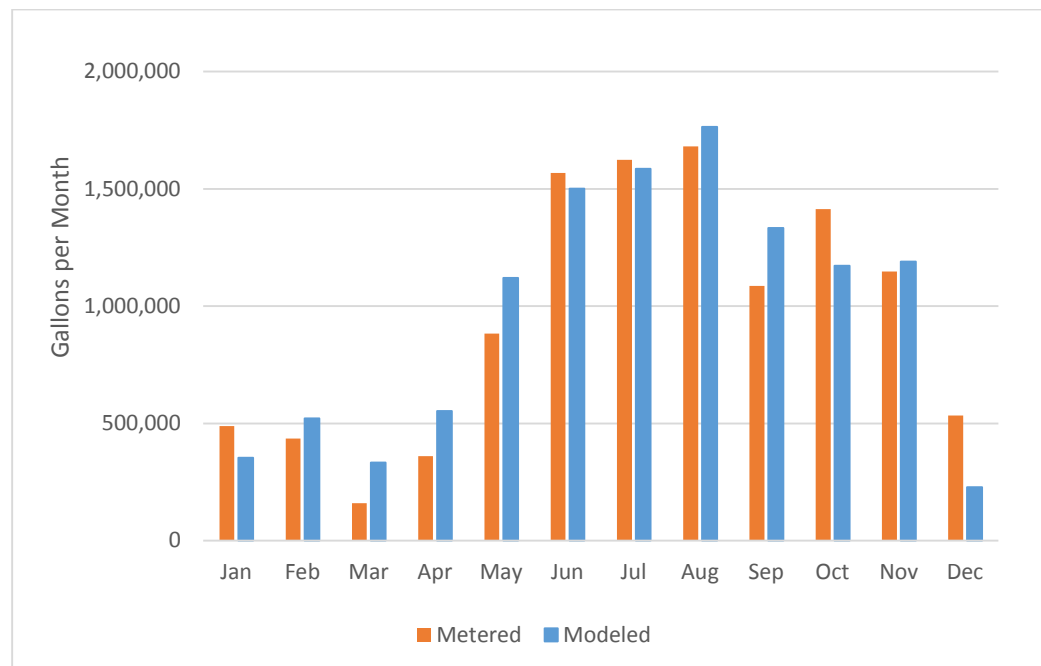

Figure 2-9. Monthly Average Modeled vs. Measured Potable Water Deliveries to Lake 2010-2015
Hollenbeck Park Lake Rehabilitation and Stormwater Management

2.6.3 Hollenbeck Park Lake Water Balance Results

From the calibrated SPAW model of HPL, average monthly outflows from HPL's outflow structures were calculated over the 2010-2015 time period. Figure 2-10 depicts the average monthly outflows ranging from 0 gallons during the summer dry season up to approximately 4,766,000 gallons during the winter wet season. The total average annual outflow is approximately 39.3 AFY.

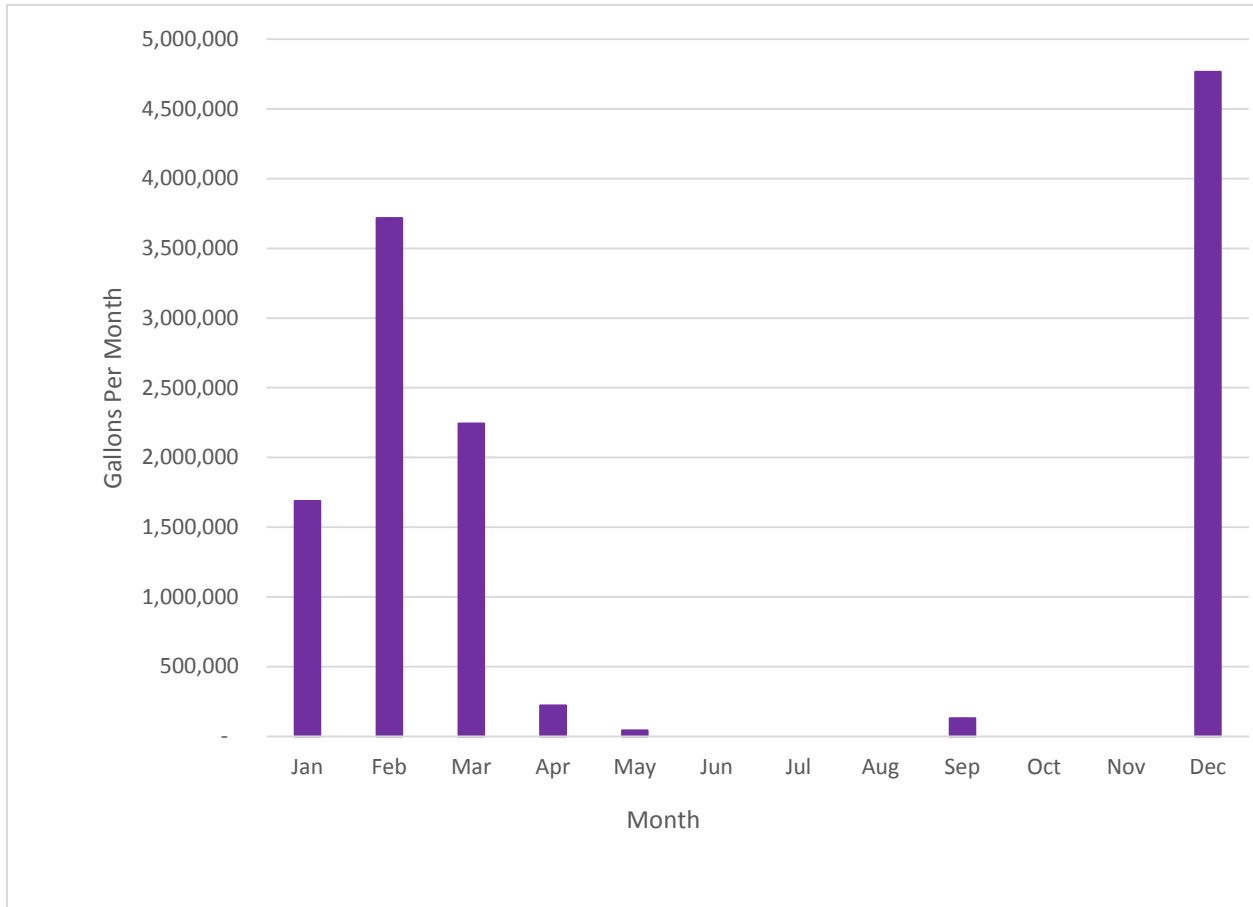

Figure 2-10. 2010-2015 Average Monthly HPL Outflows
Hollenbeck Park Lake Rehabilitation and Stormwater Management

Figure 2-11 depicts the daily modeled water levels of HPL compared to daily precipitation from January 2010 through December 2015. HPL experienced approximately 17 overflow events through its outflow weir structures (set at elevation 262.5 NAV88) over the course of the 2010-2015 period of record, or 1 to 5 events annually. As expected, overflows from HPL typically occurred during periods of larger storm events.

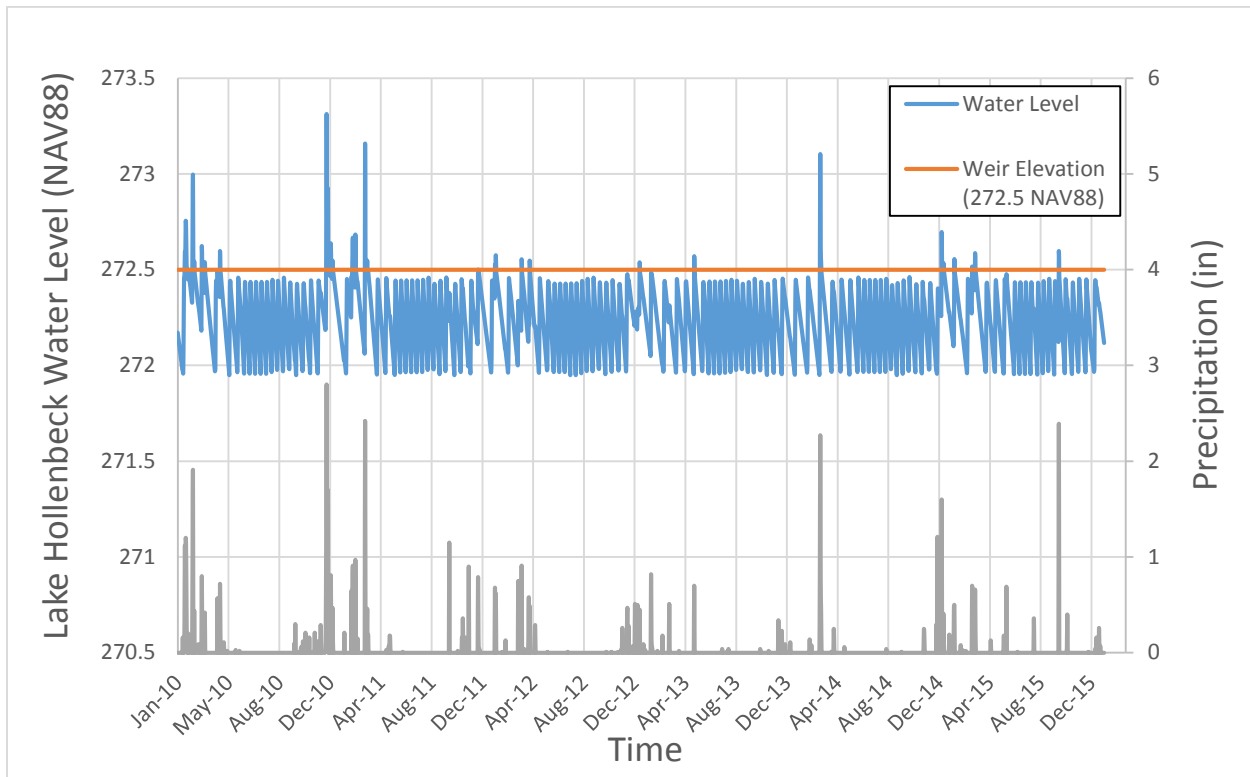

Figure 2-11. HPL Daily Water Levels and Precipitation
Hollenbeck Park Lake Rehabilitation and Stormwater Management

Finally, average monthly evapotranspiration and seepage rates were calculated from the model to evaluate losses from HPL due to evapotranspiration and infiltration. Table 2-1 below provides a monthly average of evapotranspiration and seepage rates for the 2010-2015 period of record. Monthly average evapotranspiration rates ranged from approximately 190,000 gal/month to 680,000 gal/month, and seepage rates ranged from approximately 450,000 gal/month to 970,000 gal/month. Over the 2010-2015 period of records analyzed, the average annual evapotranspiration and seepage rates from HPL equated to 16.0 and 26.4 AFY, respectively.

Table 2-1. 2010-2015 Average Monthly Modeled Evapotranspiration and Seepage Rates
Hollenbeck Park Lake Rehabilitation and Stormwater Management

Month	Evapotranspiration Rate (gal/month)	Seepage Rate (gal/month)
January	196,583	490,546
February	237,692	445,614
March	359,987	489,922
April	504,383	472,631
May	584,211	486,506
June	659,532	941,911

Table 2-1. 2010-2015 Average Monthly Modeled Evapotranspiration and Seepage Rates
Hollenbeck Park Lake Rehabilitation and Stormwater Management

Month	Evapotranspiration Rate (gal/month)	Seepage Rate (gal/month)
July	679,082	970,313
August	647,911	973,066
September	501,451	941,900
October	388,225	971,882
November	249,911	940,451
December	194,900	489,813
Annual Total (AFY)	16.0 AFY	26.4 AFY

2.7 Water Quality

HPL has a history of water quality concerns attributable to nutrient and sediment loading as well as site-specific factors. The bottom of HPL is covered with sediments that are thought to be 2 to 3 feet in depth, leaving a surface water depth in the lake interior of 3 to 6 feet. Water depths are substantially shallower at the water edge, particularly at the south end of HPL, where depths are visibly less than 2 feet.

The orientation and dimensions of HPL create a circulation pattern that responds directly to energy imparted to the water by southwesterly winds. Wind related water movement is evident in the top surface layer, and has historically led to concentration and accumulation of floatable material and algal scum in the northeast end of the lake. Water moving down from the surface likely moves south and west along HPL sediments. This pattern could yield a pattern where anaerobic, high nutrient water from the sediments is brought to the fountain intake, just off the southwest edge, and then pumped back to the center of the lake.

Limited data exist on the quality of HPL water. Visually, one can readily discern that HPL water is turbid, with a limited transparency in the order of 1 to 2 feet, indicating the presence of high populations of algal cells. Data collected in the mid-1990s reported that concentrations of the limiting nutrient total phosphorus ranged from 0.03 to 0.17 milligrams per liter (mg/L) and ammonia-nitrogen ranged from 0.18 to 0.28 mg/L. These ranges are generally lower, but in range of other lakes within the City of Los Angeles that are noted to have water quality concerns or are otherwise being managed to prevent them. For example, water quality samples collected from Echo Park Lake in 2015 showed a total phosphorus range of 0.11 to 0.29 mg/L during wet weather and 0.20 to 0.30 mg/L during non-stormwater. Similarly, total Kjeldahl nitrogen, a measure of organic- and ammonia-nitrogen, ranged from 1.4 to 1.9 mg/L during wet weather and 0.66 to 3.21 mg/L during non-stormwater. Given that two decades have passed since the operation of the treatment systems installed at HPL with the exception of the fountain recirculation system, it is highly likely that sediment has deepened and that internal cycling of nitrogen and phosphorus from the sediments to the water column continues within HPL, thereby elevating algal populations and contributing to a deterioration in lake water quality.

2.7.1 Previous Improvements

The *Hollenbeck Lake Conceptual Design Report* prepared in 1995 outlines previous improvements to address the poor water quality at HPL (RBF, 1995). In 1997, a recirculation/aeration treatment system that includes an inlet structure, pumps, and fountains was implemented at HPL. A chemical treatment

system for alum and sodium hydroxide was also constructed as part of the improvements. Once constructed, the chemical feed system was never turned on and the equipment remains unused.

2.7.2 Current Improvements

As the first step in the implementation of HPL rehabilitation system to address lake water quality, five floating wetland islands (FWIs) were installed in June 2015, each comprised of five mats each. Additional floating wetland islands, aeration system components, and the refurbishment of the existing alum injection system are in consideration for installation in 2016 as discussed in Section 4.

Water Supply Alternatives Analysis

Replacement of potable water demand at Hollenbeck Park and downstream facilities will help meet water conservation goals and achieve a truly sustainable water solution for the watershed. Four alternative sources of water were considered for the Project, including the Los Angeles River, Los Angeles Department of Water and Power (LADWP) recycled water, sewer mining, and HPL overflows/non-stormwater flows.

3.1 Water Demand

Seasonal water demands for each component of the Project were calculated. A table and graph of the average monthly demands are shown in Table 3-1 and Figure 3-1. The annual water demand for the Project totals 74.1 AFY.

Hollenbeck Park – Water demand at Hollenbeck Park was based on potable water delivery records provided by LA Parks for a period from June 2014 through February 2016. Records included deliveries to the park’s irrigation system, lake, bathrooms, recreation center, drinking fountains and stage. However, only the water used for irrigation and lake replenishment were considered to be replaced by a non-potable source.

6th Street Viaduct, Pocket Park, Wetlands, Roundabout – Irrigation demands at the 6th Street Viaduct parklands and Mission/Jesse intersection (including the pocket park, wetlands, and roundabout) were based on the Simplified Landscape Irrigation Demand Estimation (SLIDE) methodology by the University of California, Division of Agriculture and Natural Resources Center for Landscape and Urban Horticulture (University of California, 2016). This approach estimates landscape water demands based on local seasonal evapotranspiration rates, plant factor, and landscaped area. A plant factor of 0.65 was used for all locations as a median water use number for landscaping.

Mission/Jesse ATF – LASAN staff indicated a potable water use of 10,500 gallons per day for continuous operation of the bio-trickling filters. This amounts to approximately 11.8 AFY.

Table 3-1. Seasonal Water Demands*Hollenbeck Park Lake Rehabilitation and Stormwater Management*

	January (gal/ month)	February (gal/ month)	March (gal/ month)	April (gal/ month)	May (gal/ month)	June (gal/ month)	July (gal/ month)	August (gal/ month)	September (gal/ month)	October (gal/ month)	November (gal/ month)	December (gal/ month)	Annual (AFY)
Hollenbeck Park Irrigation	307,054	183,260	120,428	204,952	152,966	224,400	777,920	709,104	593,912	501,534	358,292	117,436	13.0
HPL	353,524	521,489	332,563	553,040	1,120,199	1,501,582	1,585,592	1,764,091	1,333,563	1,172,549	1,190,253	227,483	35.8
Hollenbeck Park Subtotal	660,578	704,749	452,991	757,992	1,273,165	1,725,982	2,363,512	2,473,195	1,927,475	1,674,083	1,548,545	344,919	48.8
6th Street Viaduct Irrigation	138,590	166,904	254,082	357,652	415,770	469,418	485,065	461,967	357,652	277,180	178,826	138,590	11.4
ATF (Treatment)	320,545	320,545	320,545	320,545	320,545	320,545	320,545	320,545	320,545	320,545	320,545	320,545	11.8
ATF Pocket Park	10,545	12,699	19,332	27,213	31,635	35,717	36,907	35,150	27,213	21,090	13,606	10,545	0.9
Mission/Jesse Roundabout	3,314	3,991	6,076	8,553	9,942	11,225	11,599	11,047	8,553	6,628	4,276	3,314	0.3
Dragonfly Wetlands	11,675	14,060	21,404	30,128	35,024	39,543	40,861	38,916	30,128	23,349	15,064	11,675	1.0
Irrigation Subtotal	25,534	30,750	46,812	65,893	76,601	86,485	89,368	85,112	65,893	51,067	32,947	25,534	2.1
ATF Subtotal	346,079	351,296	367,357	386,439	397,147	407,031	409,913	405,658	386,439	371,613	353,492	346,079	13.9
Total Water Demand	1,145,247	1,222,949	1,074,430	1,502,083	2,086,082	2,602,431	3,258,490	3,340,820	2,671,566	2,322,876	2,080,863	829,588	74.1

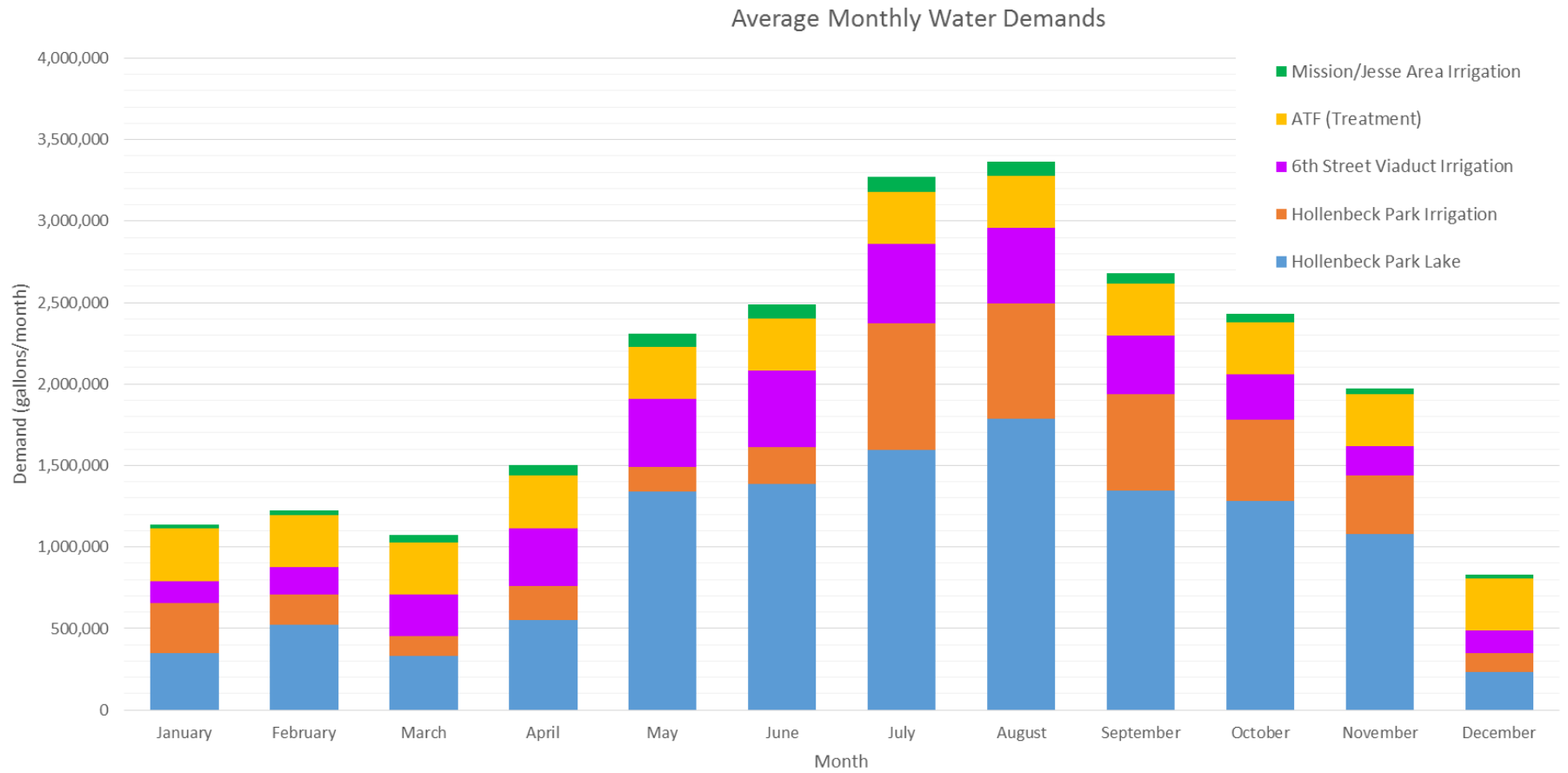

Figure 3-1. Average Monthly Water Demands
Hollenbeck Park Lake Rehabilitation and Stormwater Management

3.2 Regulatory Setting

This section provides a brief review of applicable federal, state, and local regulations followed by a preliminary identification of potential permits or regulatory approvals required before the Project components can be constructed.

3.2.1 Federal

Clean Water Act

The Clean Water Act (CWA) (33 USC 1251 et seq.) was enacted with the intent of restoring and maintaining the chemical, physical, and biological integrity of Waters of the U.S. The CWA requires states to set standards to protect, maintain, and restore water quality through the regulation of point source and specific nonpoint pollution source discharges to surface water.

Section 401. Section 401 of the CWA requires that any activity, including the crossing of rivers or streams during road, pipeline, or transmission line construction, that might result in discharges of dredged or fill material into a state water body, be certified by the Regional Water Quality Control Board (RWQCB). This certification ensures that the proposed activity does not violate state or federal water quality standards. In addition, a water quality certification (or waiver thereof) pursuant to Section 401 of the CWA would also be required from the applicable RWQCB, for issuance of federal approval under Section 404 (see Section 404, below).

Section 402. Under Section 402 of the CWA, the State Water Resources Control Board (SWRCB) and/or the applicable RWQCB issues National Pollutant Discharge Elimination System (NPDES) Permits for discharges (point source, and non-point source such as storm water) into surface Waters of the U.S. The NPDES Program is a federal program, which has been delegated to the State of California for implementation through the State Water Resources Control Board (SWRCB) and the nine RWQCBs. In California, NPDES permits are also referred to as waste discharge requirements (WDRs) that regulate discharges to Waters of the State, including groundwater (see Porter-Cologne Water Quality Control Act, below).

Section 404. Section 404 of the CWA authorizes the U.S. Army Corps of Engineers (USACE) to regulate the discharge of dredge or fill material to the Waters of the U.S., including wetlands. The limits of non-tidal waters extend to the ordinary high water mark, which is defined as the line on the shore established by the fluctuation of water and indicated by physical characteristics, such as a natural line impressed on the bank, changes in the character of the soil, and presence of debris. USACE may issue either individual, site-specific permits, or general or nationwide permits for discharge into Waters of the U.S. In addition, a water quality certification (or waiver thereof) pursuant to Section 401 of the CWA would also be required from the applicable RWQCB, as required under Section 404, prior to issuance of a 404 Permit.

Section 408. Section 408 of the CWA requires that any project that affects a facility built by USACE will require their approval. USACE will require that a permit (known as a 408 Permit) be obtained for the proposed improvements affecting the federally-built facility or its rights of way.

National Environmental Policy Act

The National Environmental Policy Act (NEPA) requires all federal agencies that make discretionary approvals of proposed actions. These requirements apply when the action is proposed by the federal agency or when another public or private entity's proposed action is being approved, permitted, funded (in whole or in part), or otherwise authorized by a federal agency. If the proposed action does not fit within a NEPA Categorical Exclusion, the federal agency must prepare an Environmental Assessment (EA). If the EA does not identify a significant impact the federal agency will prepare a Finding of No

Significant Impact (FONSI). If the proposed action will have significant impacts on the human environment, an Environmental Impact Statement must be prepared.

3.2.2 State

Porter-Cologne Water Quality Control Act

The Porter-Cologne Water Quality Control Act of 1967 (California Water Code Section 13000 et seq.) requires the SWRCB and the nine RWQCBs to adopt water quality criteria to protect state waters. These criteria include the identification of beneficial uses, narrative and numerical water quality standards, and implementation procedures.

The *Water Quality Control Plan for the Los Angeles Basin* (Los Angeles RWQCB, 1994) establishes water quality standards for the Los Angeles basin, which includes the proposed project. Water quality standards include designated beneficial uses for surface water and groundwater, and narrative or numeric water quality objectives to protect those beneficial uses. The plan also includes implementation plans describing the actions by the Los Angeles RWQCB and others that are necessary to achieve and maintain the water quality standards.

California Department of Fish and Wildlife.

The California Department of Fish and Wildlife (CDFW) is responsible for conserving, protecting, and managing the California fish, wildlife, and native plant resources. To meet this responsibility, the Fish and Game Code (Section 1602) requires an entity to notify the CDFW of any proposed activity that might substantially modify a river, stream, or lake. The CDFW issues Streambed Alteration Agreements (SAAs) to conditionally permit activities affecting rivers, streams, or lakes.

Title 22 California Code of Regulations

Title 22 of California's Water Recycling Criteria refers to California state guidelines for how treated and recycled water is discharged and used. The standards also require the California Department of Public Health (CDPH) to develop and enforce water and bacteriological treatment standards for water recycling and reuse. State discharge standards for reclaimed water and its reuse are regulated under the Water Recycling Criteria and the 1969 Porter-Cologne Water Quality Control Act. Effluent treatment standards are set and enforced by the RWQCB in consultation with the CDPH, and allow use of disinfected tertiary recycled water for irrigating parks, among other uses.

Section 1211 of the Water Code

Section 1211 of the Water Code requires that before making a change in the point of discharge, place of use, or purpose of use of treated wastewater, the owner of the treatment plant must seek approval from the Division of Water Rights, which is accomplished by filing a Petition for Change for Owners of Waste Water Treatment Plants (Petition for Change). To determine whether it is necessary to file a petition with the Division of Water Rights, an agency may discuss a proposed water pollution control or water recycling project with staff in the Division of Water Rights. Based on this discussion, the Division of Water Rights will issue a letter of determination whether no further action is required or a petition must be filed.

Pueblo Water Rights

In California, water rights law is administered by the SWRCB. Within the SWRCB, the Division of Water Rights acts on behalf of the State Water Board for day to day matters. California recognizes several different types of rights to take and use surface water. Some water rights can only be held by government. These include pueblo rights, which can only be held by municipalities that were originally Mexican or Spanish pueblos, such as the City of Los Angeles. In particular, the City of Los Angeles has pueblo water rights to Los Angeles River water within the City for City use. Hence, diversion of Los Angeles River water by the City of Los Angeles for City use does not require State of California

approval under the SWRCB’s water appropriation permitting process. Diversion would likely require inter-city agreement between LASAN and the LADWP.

California Environmental Quality Act

The California Environmental Quality Act (CEQA) requires state and local agencies to identify the significant environmental impacts of their actions and to avoid or mitigate those impacts, if feasible. A public agency must comply with CEQA when it undertakes an activity defined by CEQA as a “project.” A project is an activity undertaken by a public agency or a private activity that must receive some discretionary approval (meaning that the agency has the authority to deny the requested permit or approval) from a government agency, which may cause either a direct physical change in the environment or a reasonably foreseeable indirect change in the environment. If the proposed project does not fit within a CEQA Categorical or Statutory Exemption, an Initial Study (IS) must be conducted by the lead agency to determine if a project may have a significant effect on the environment. If the IS does not identify a significant impact, the lead agency will prepare a Negative Declaration (ND) or Mitigated Negative Declaration (MND). If the proposed project will have significant impacts on the environment that cannot be mitigated to below a level of significance, an Environmental Impact Report must be prepared.

3.2.3 Local

Municipal National Pollutant Discharge Elimination System Program.

Municipalities are required under Section 402(p) of the CWA to develop programs to monitor and control pollutants in stormwater discharges from their municipal systems. Such control might include regulation of stormwater discharges from industrial and commercial facilities that the municipality determines are contributing pollutants to the municipal storm drain system.

In 2012, the Los Angeles RWQCB adopted Order R4-2012-0175, the MS4 Permit for Los Angeles County. In 2015, the MS4 Permit was amended per State Water Board Order WQ 2015-0075. The MS4 Permit dictates stormwater and non-stormwater discharge requirements for the LACFCD, Los Angeles County, and 84 permittee cities including the City of Los Angeles.

Los Angeles Department of Public Health. Regulations are established by the Los Angeles County Department of Public Health (LACDPH) for the use of non-potable water. Non-potable water in Los Angeles County is limited to use that is approved by the CDPH, Los Angeles RWQCB, and the LACDPH. Any unauthorized use of non-potable water is prohibited. LACDPH regulations also include review and approval authority over storm drain water diverted for irrigation or other uses.

Los Angeles County Flood Control District. The LACFCD is responsible for managing flood risk and conserving stormwater for groundwater recharge. The LACFCD also provides control of debris, collection of surface stormwater from streets, and replenishes groundwater with stormwater and imported and recycled waters. It is a special district governed by the County of Los Angeles Board of Supervisors, and its functions are carried out by the Los Angeles County Department of Public Works. In order to continue to fulfill these responsibilities and maintain the existing level of service, any proposed construction within the LACFCD right-of-way requires approval from the LACFCD.

3.2.3.1 Potential Permits or Regulatory Approvals

Early consultation with regulatory agencies is recommended to further identify and refine the requisite permits or regulatory approvals that may be required for project alternative implementation. Preliminary identification of potential permits or regulatory approvals that may be required for each source alternative is described below.

3.3 Alternative 1: Los Angeles River

3.3.1 Flow Analysis

The Los Angeles River is approximately 55 miles long and has a highly urbanized watershed of 834 square miles. Average non-stormwater flows near the terminus of the river in Long Beach are 153 cfs, which can double or triple during wet weather (LASAN, 2016). Non-stormwater flows within the river are a combination of urban runoff, groundwater, and tertiary treated effluent from Donald C. Tillman Water Reclamation Plant, Los Angeles-Glendale Water Reclamation Plant, and Burbank Water Reclamation Plant.

The Los Angeles River Cooperation Committee (LARCC) was founded in 2010 and is a working group between a number of agencies including the City of Los Angeles and the LACFCD in conjunction with the United States Army Corps of Engineers. The purpose of the Los Angeles River Cooperation Committee is to evaluate, prioritize, and make recommendations about projects along the upper reach of the Los Angeles River. The LARCC will evaluate projects and make collaborative decisions to recommend a project as proposed, recommend a project with modifications, or not recommend a project. Key factors evaluated include community benefits and support, hydraulics and hydrologic considerations, water quality impacts, water and energy conservation improvements, habitat connectivity, and safety/security impacts as well as operations, maintenance, and liability requirements.

The LARCC is comprised of the following members:

- City Engineer of the City of Los Angeles (co-chair)
- Chief Engineer of the LACFCD (co-chair)
- Director of LASAN
- The City of LA Department of Recreation and Parks
- The City of Los Angeles Department of Water and Power
- The LACFCD Watershed Management Division
- The LACFCD Water Resources Division
- The LACFCD Flood Maintenance Division
- USACE (to serve on the LARCC in an advisory capacity)

The Los Angeles River alternative as described in this concept report will be submitted to the LARCC for review. A preliminary analysis has been conducted to compare Los Angeles River flows to Project demands. Table 3-2 shows the average Los Angeles River flows measured 800 feet above the Arroyo Seco confluence. The table also shows the Project's demand as a percentage of the seasonal flows in the river, which range from 0.02 to 0.17 percent.

Table 3-2. Los Angeles River Average Flows at Arroyo Seco Station F57C from October 2012 to January 2016
Hollenbeck Park Lake Rehabilitation and Stormwater Management

Month	Los Angeles River Flows (cfs)	LA River Flows (gallon/month)	Demand as Percent of Flows
January	207	4,074,719,109	0.03
February	226	4,440,147,149	0.03
March	206	4,053,762,662	0.03
April	101	1,990,862,438	0.08
May	123	2,409,991,373	0.09
June	102	2,001,340,662	0.13
July	132	2,599,909,171	0.13
August	97	1,902,452,429	0.18
September	166	3,260,037,243	0.08

Table 3-2. Los Angeles River Average Flows at Arroyo Seco Station F57C from October 2012 to January 2016
Hollenbeck Park Lake Rehabilitation and Stormwater Management

Month	Los Angeles River Flows (cfs)	LA River Flows (gallon/month)	Demand as Percent of Flows
October	102	2,003,469,051	0.12
November	120	2,354,653,256	0.09
December	194	3,809,980,247	0.02

3.3.2 Conceptual Design

3.3.2.1 Los Angeles River Intake Pump Station

The Los Angeles River intake pump station will capture river flows and deliver the water to Hollenbeck Park, 6th Street Viaduct parklands, and the Mission/Jesse area. The conceptual design to divert flows includes an intake structure, a 6-foot-diameter wet well, duplex submersible pumps, and NEMA 4X electrical controls panel. The intake pump control system includes timer control, and the desired pumping matrix will be manually set at the pump control panel. A flowmeter on the discharge side of the intake pump will be used to record the flow. The intake flowmeter will be equipped with a real-time display indicating the flow rate and flow totalizer.

Pump Station Design and Hydraulics

For the design flow of the pump station, the peak demand months of July and August are used to size the pump. Table 3-3 shows the total average flow rate requirement for each month at continuous bases.

Table 3-3. Monthly Flow Demand at Los Angeles River
Hollenbeck Park Lake Rehabilitation and Stormwater Management

Month	Jan	Feb	Mar	Apr	May	Jun	July	Aug	Sept	Oct	Nov	Dec
Flow demand (gal/minute)	25.1	25.5	26.3	36.9	49.7	57.6	79.6	75.1	62.6	56.2	45	22

To minimize energy costs, the pump station is assumed to only run during the non-peak hours for 10 hours per day during nighttime. A continuous flow demand of 79.6 gal/minute is the highest in July. When operating 10 hours per day, the pump flow rate will be 191 gal/minute.

Pump Sizes and Pump Selection

Based on the total combined water demand for the Project, the submersible pumps will be sized for 200 gal/minute at 85 feet total dynamic head considering the elevation change (about 68 feet) and piping losses.

Based on the site conditions, the station will be constructed below grade on the river slope. It is recommended that submersible pumps with a wet well be installed. The pumps will be 10 horsepower (hp) each, with one operating and one standby. The pumps will be equipped with base elbows and guide rails for easy installation and removal.

Actual pump total dynamic head will be calculated as part of final design and development of the overall pumping system curve. For the purpose of this conceptual report, the total dynamic head is estimated for determining the pump size and corresponding costs.

Pump Station Configuration.

The pump station design will have redundancy to maintain overall system reliability. A standby pump allows for continuous station operation in the event of pump failure by the duty pump. The two pumps will run equally to maintain equal wear.

The wet well can be designed as either cast-in-place or pre-cast structure, and will be designed to meet Hydraulic Institute Standards. Details will be developed as part of the final design. Initial assessments indicate that a 6-foot-diameter by 12-foot-deep wet well will be sufficient to accommodate two 10-hp submersible pumps.

The intake structure will be located at the dry-weather flow area (lowest part of the river bed) and designed to keep debris and silt from entering the wet well. Intake structure details will be developed in the detailed design phase.

The wet well will be located on the lower part of the river slope with grating access on the top, and the wet well top will be flush with the river slope as shown on Figure 3-2.

Pump Station Operation Controls

For operational controls, a timer controller will control the start time and pump running duration each day and is operator adjustable. The following float level switches will turn off the pump at low water level in the wet well or during the storm event when the water level is high in the wet well:

- Low Level – Pump Off
- High Level – Pump Off during storm event

Utility Power

It is expected that power for the pump station will be available from a nearby power source. The connection to utility power will be coordinated with Southern California Edison.

3.3.2.2 Conveyance and Water Quality

Once pumped from the Los Angeles River, flows need to be distributed to Hollenbeck Park, 6th Street Viaduct, and the Mission/Jesse area. Figure 3-3 shows the proposed conveyance for a 4-inch pipe under this alternative, which will require approximately three sections of bore and jack including freeway and railroad crossings.

To install the pipe through Caltrans right-of-way to cross the US-101, I-5, and I-10 freeways, existing City of Los Angeles rights-of-way can be utilized. There is an existing 15-foot City easement that crosses these freeways. The easement also runs through an existing public storage lot. The easement currently has a 20-inch sewer line as well as a 45-inch City storm drain at a 5-foot southern offset as shown on Figure 3-4. Several alternative alignments were considered; however utilization of this existing City easement is preferred. Within the easement, a 20-inch VCP sewer main including active and abandoned segments. The abandoned segments are located below the freeway crossings and may provide an opportunity to be used as a casing for the tunneling operations.

Los Angeles River water is considered urban runoff and therefore needs to undergo treatment processes before the water can be used for irrigation. Due to limited space near the Los Angeles River, separate pretreatment, storage, and processing is recommended at each project area: Hollenbeck Park, 6th Street Viaduct parklands, and Mission/Jesse area.

Once flows are pumped from the Los Angeles River, the main distribution line will convey water to Hollenbeck Park to be delivered to HPL via the shoreline wetlands treatment described in Section 5.2. A new submersible pump will be placed in the existing wet well, adjacent to the existing pump used for HPL's fountains as shown on Figure 3-5. Water from HPL will then be pumped through the processing system before distribution to HPL's irrigation system.

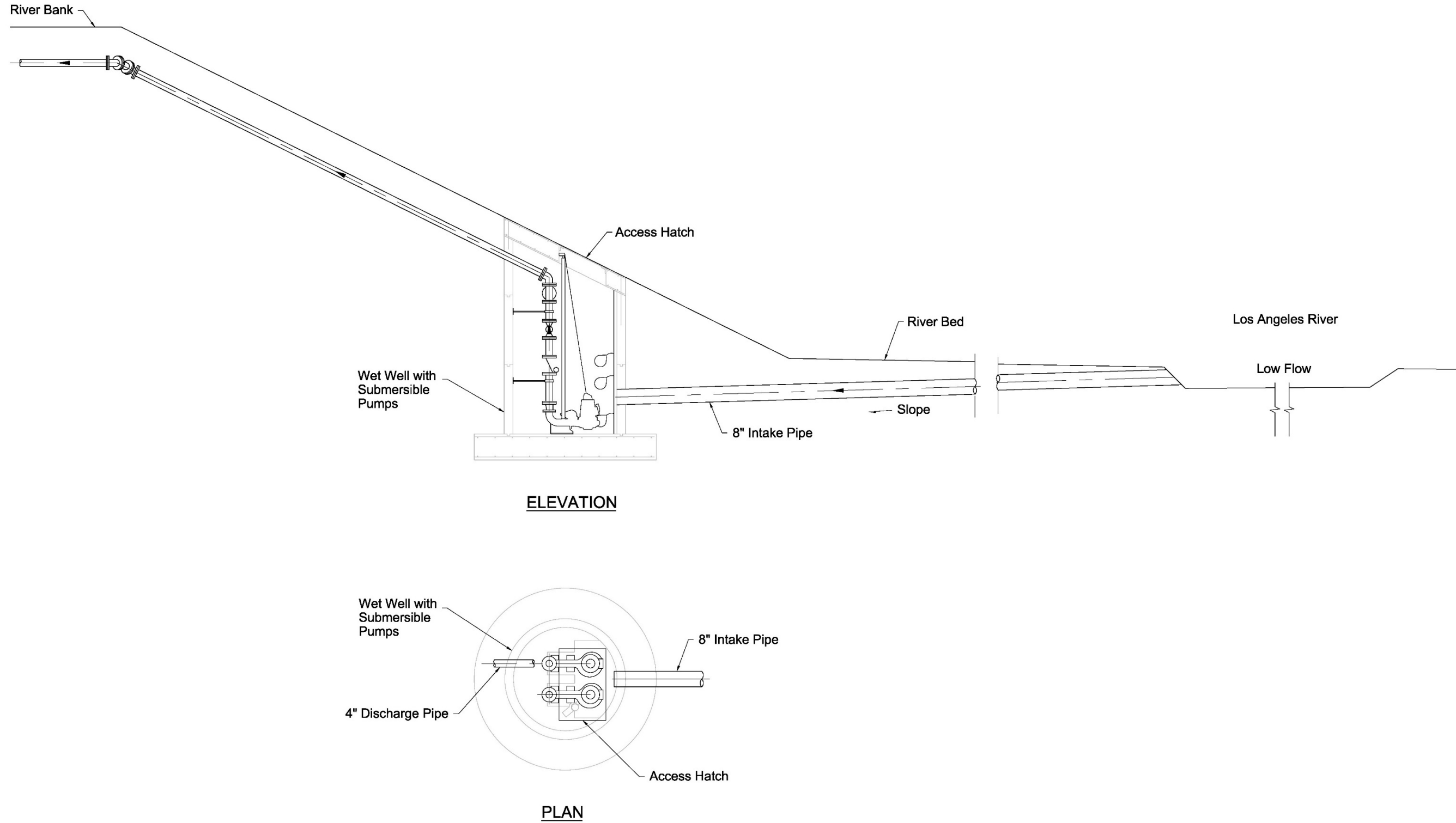

Figure 3-2. Los Angeles River Intake Structure Conceptual Design, Water Supply Alternative: Los Angeles River
Hollenbeck Park Lake Rehabilitation and Stormwater Management



Figure 3-3. Conceptual Conveyance Alignment, Water Supply Alternative: Los Angeles River Hollenbeck Park Lake Rehabilitation and Stormwater Management

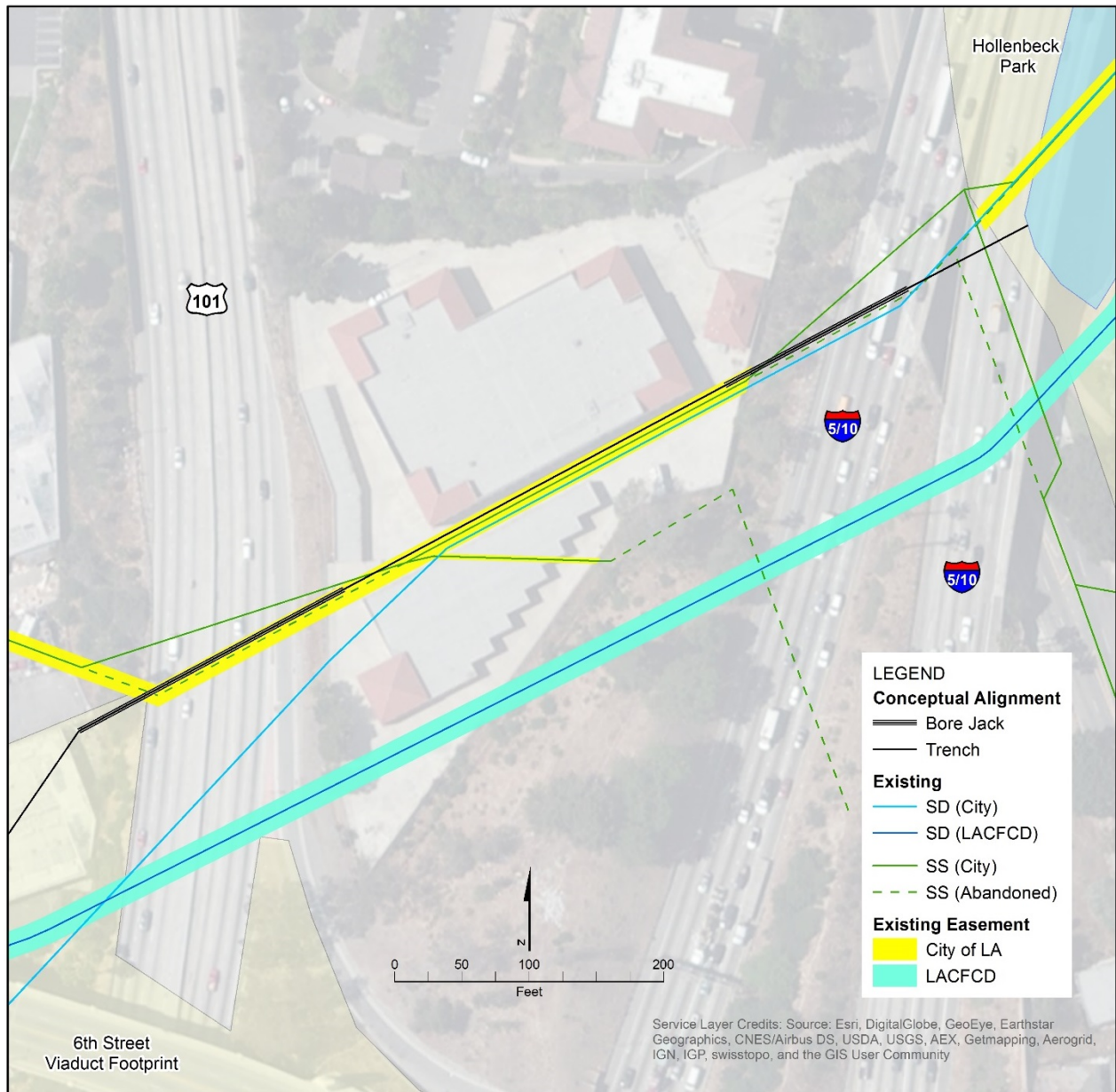

Figure 3-4. Conceptual Alignment for Freeway Crossing and Existing Easements
Hollenbeck Park Lake Rehabilitation and Stormwater Management

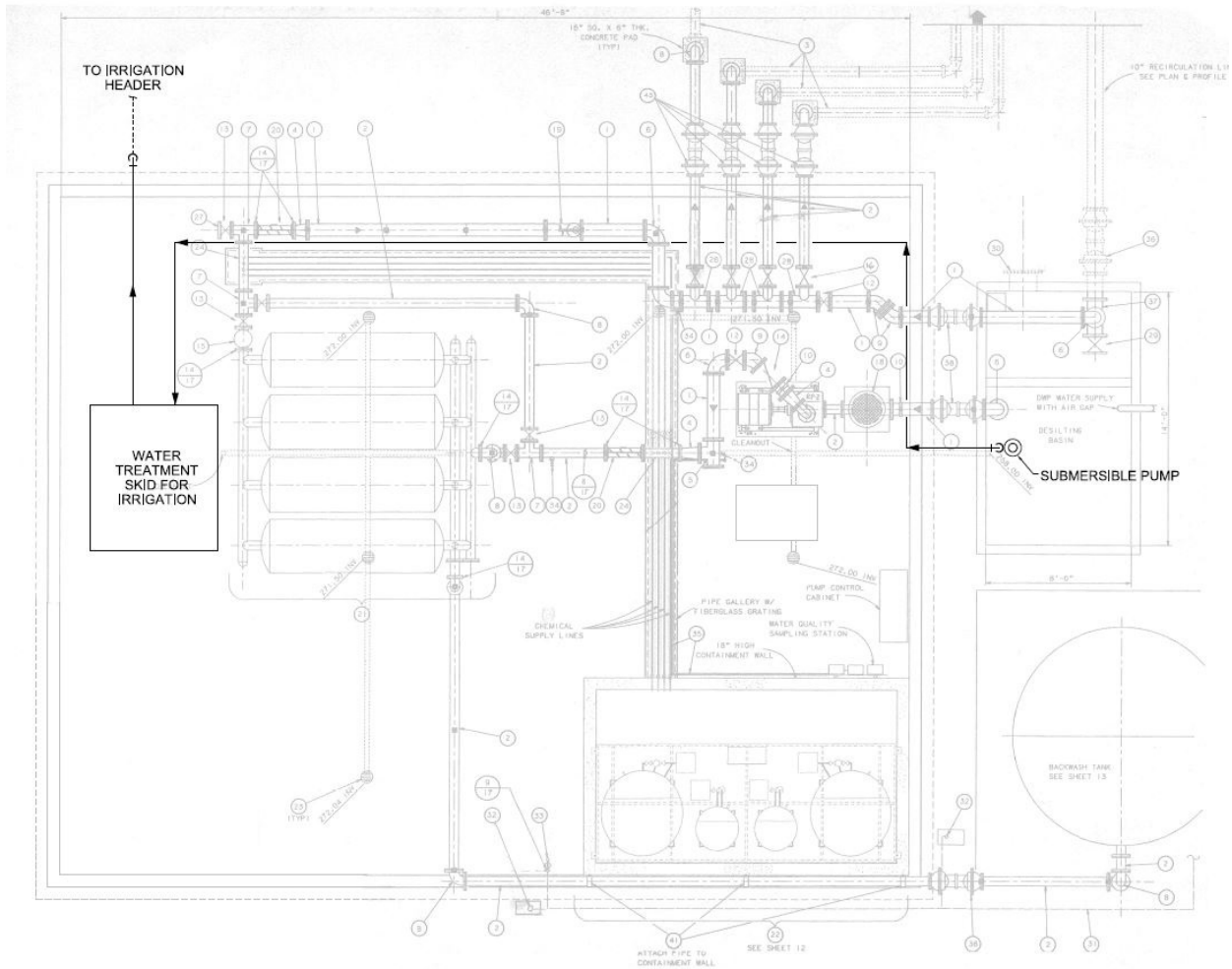

Figure 3-5. Irrigation Pump at Existing Chemical Feed System, Water Supply Alternative: Los Angeles River
Hollenbeck Park Lake Rehabilitation and Stormwater Management

Two connections to the Los Angeles River/HPL distribution line are needed to deliver flows to the 6th Street Viaduct parklands and Mission/Jesse area. These flows will be pretreated prior to storage in the underground cisterns at each site. Stored water will then be pumped through the processing system and distributed as irrigation water at each site. Since operation of the irrigation system will require a different pumping schedule than the ATF needs, a second cistern and pump is recommended to deliver water to the ATF. Figure 3-6 shows the process flow diagram of the Los Angeles River water supply alternative.

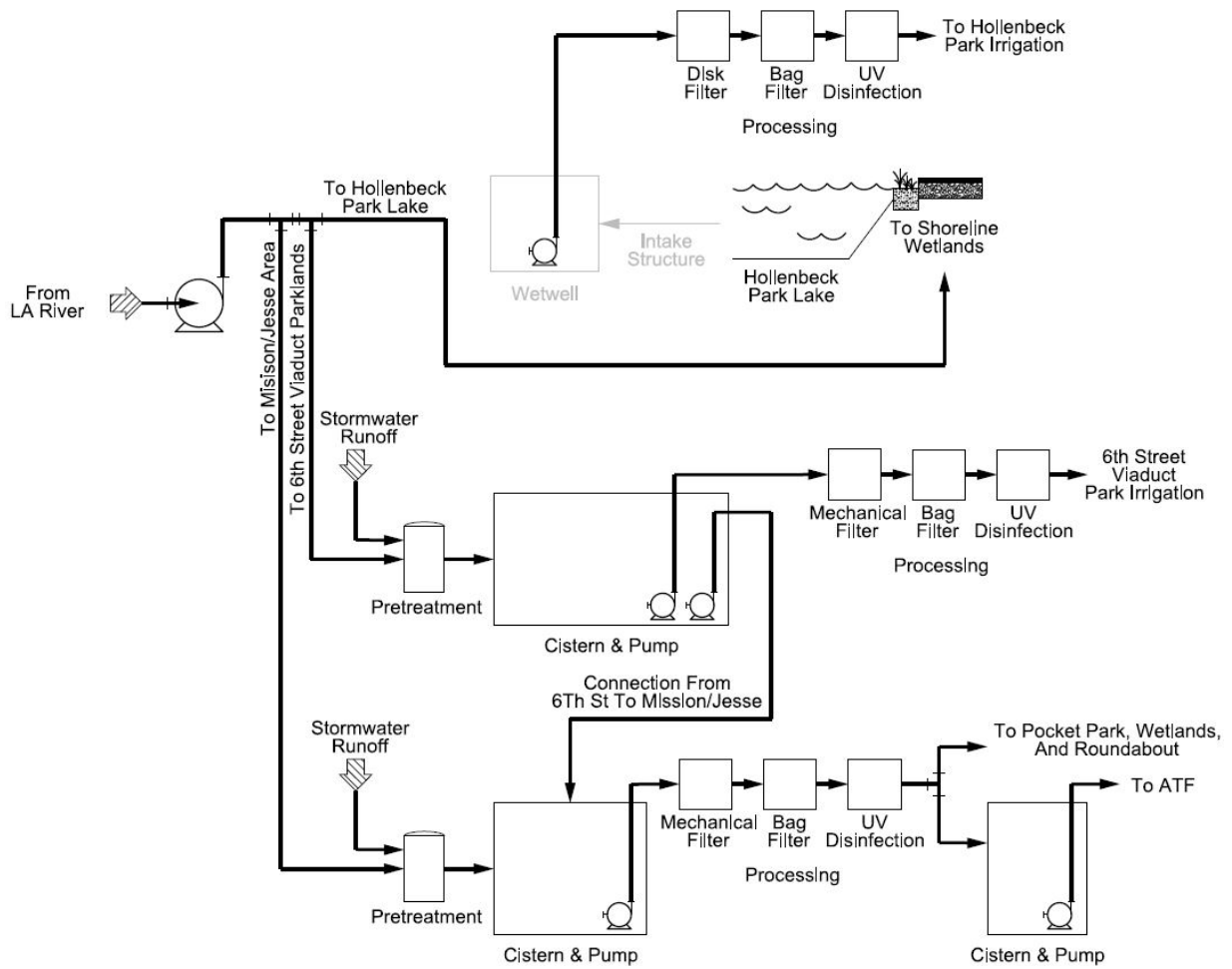

Figure 3-6. Process Flow Diagram, Water Supply Alternative: Los Angeles River
 Hollenbeck Park Lake Rehabilitation and Stormwater Management

3.3.3 Permitting

Table 3-4 includes preliminary identification of potential permits or regulatory approvals that may be required for the Los Angeles River water supply alternative.

Table 3-4. Preliminary Summary of Environmental Permits/Approvals for Los Angeles River Source Alternative
Hollenbeck Park Lake Rehabilitation and Stormwater Management

Activity	Permit/Approval	Acquisition Schedule
Los Angeles River intake structure	<p>Federal</p> <ul style="list-style-type: none"> - USACE CWA Section 404 Permit (dredge and fill) and associated NEPA review (likely an EA/FONSI) - USACE 408 Permit for alteration or occupation or use of a USACE civil works project and associated NEPA review (likely an EA/FONSI) <p>State</p> <ul style="list-style-type: none"> - RWQCB, (Region 4) CWA Section 401 Water Quality Certification for intake structure activities within the Los Angeles River. - CDFW 1602 SAA for intake structure and activities within River. Coordination with CDFW is recommended to confirm applicability; SAA is not applicable if activity does not substantially divert or obstruct natural flow, change or use material from the bed, or deposit debris, waste or other material in the river. - RWQCB General NPDES Permit for discharges of construction and project dewatering to surface waters (NPDES No. CAG994004). 	<p>Federal</p> <ul style="list-style-type: none"> - 404 Permit, including NEPA EA/FONSI: 12 – 18 months - 408 Permit, including NEPA EA/FONSI: 12 – 24 months <p>State</p> <ul style="list-style-type: none"> - 401 Certification: 4 – 6 months - 1602 SAA: 4 – 6 months - RWQCB coverage under dewatering General Permit: 2 – 3 months
Diversion of Los Angeles River water for source water use at lake and for park irrigation and for use at Dragonfly Wetlands and Pocket Park (water rights)	City of Los Angeles has “Pueblo Water Rights” to Los Angeles River water within the City for City use. Hence, diversion of Los Angeles River water by the City for City use does not require State of California approval under the SWRCB’s water appropriation permitting process. Diversion would likely require inter-City agreement between the LA SAN and the City of Los Angeles Department of Water and Power.	Inter-city agreement process would be initiated by contacting Greg Reed/Los Angeles Department of Water and Power.
Use (discharge) of Los Angeles River water to lake and park irrigation	SWRCB and/or RWQCB Region 4: Use (discharge) of River water to lake and park irrigation may require a discharge permit (e.g., WDR and/or NPDES).	6 – 12 months
Project undertaking as a whole (i.e., pump stations, river water conveyance pipeline, chemical storage/feed, storm drain diversion)	<ul style="list-style-type: none"> - CEQA environmental review and public disclosure. An (IS/MND would likely be adequate.^a - NPDES General Permit for storm water discharges associated with construction activities. Applicable to construction activities consisting of one acre or more of disturbance and includes developing a Storm Water Pollution Prevention Plan and implementing best management practices and conducting inspection during construction. A Notice of Intent (NOI) must be submitted to the SWRCB to obtain coverage under the General Permit. 	<ul style="list-style-type: none"> - CEQA (IS/MND): 6 – 9 months - SWRCB coverage under General Permit: 1 – 2 months

Notes:

^a Issuance of State Permits (unless an already authorized general order) typically require CEQA review.

3.3.4 Cost

To provide a cost comparison of water supply alternatives, a construction cost estimate was prepared to show costs specific to the Los Angeles River water supply alternative. Construction costs were estimated for the project components unique to the Los Angeles River water supply alternative and do not reflect the other recommendations noted in Section 5. The following components were included in this estimate, including markup:

- Intake structure and pump station
- Conveyance of 4-inch ductile iron pipe including bore and jack sections
- Cistern and pump at Mission/Jesse intersection
- Pump and processing equipment to treat lake water for irrigation

The estimated cost for only the Los Angeles River water supply alternative is \$2,508,726 for alternative specific components. The basis of design for all cost estimates is presented in Section 6.1.

3.4 Alternative 2: LADWP Recycled Water

3.4.1 Flow Analysis

The LADWP is proposing the Downtown Water Recycling Project (DTWRP) to expand the availability of recycled water in the area and is projected to be complete construction in 2020. The DTWRP proposes a mainline segment along San Pedro Street that branches to Boyle Heights along Olympic Boulevard. However, a major hurdle of the Boyle Heights alignment is crossing the Los Angeles River and railroad corridor through the historic Olympic Boulevard Bridge. LADWP is currently considering an alternative recycled water line through the 6th Street Viaduct right-of-way as shown on Figure 3-7. This alternative alignment is the basis for evaluation of recycled water as a source of water for this project. If the DTWRP does not move forward with the alternative recycled water alignment, the Project would have to connect to Olympic Boulevard, which has not been analyzed in this concept report.

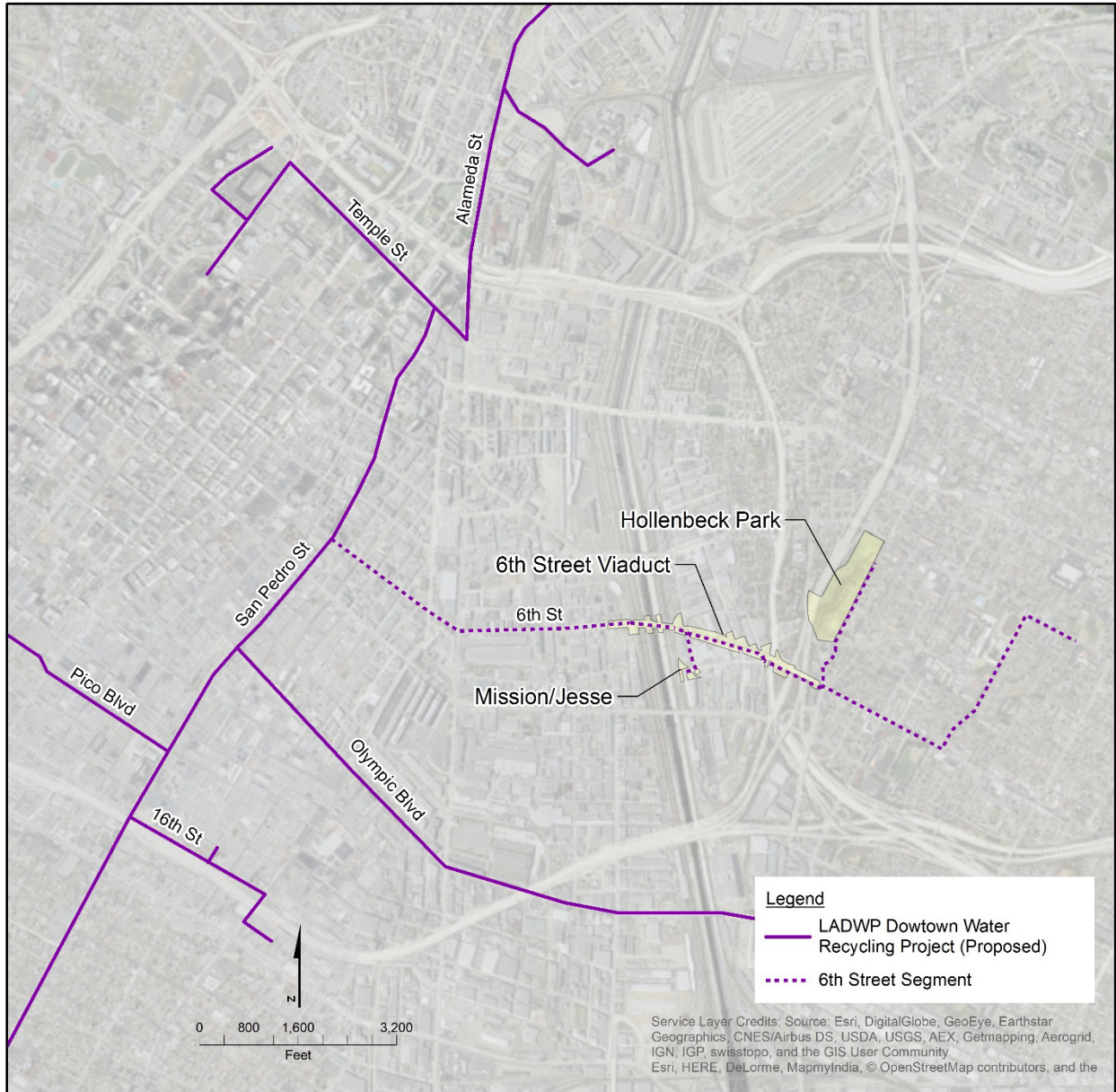

Figure 3-7. Proposed DTWRP and 6th Street Connection, Water Supply Source: LADWP Recycled Water Hollenbeck Park Lake Rehabilitation and Stormwater Management

3.4.2 Conceptual Design

As part of the recycled water distribution system, LADWP will own and operate the conveyance infrastructure and the Project will utilize service connections to this system to deliver flows to Hollenbeck Park, 6th Street Viaduct parklands, and the Mission/Jesse area. A 16-inch distribution pipe is needed to serve the recycled water demand of the area, including the Project as well as surrounding potential users. The proposed conceptual alignment for this pipeline is shown on Figure 3-8.

LADWP recycled water meets irrigation water quality standards and can be connected directly to the irrigation system at Hollenbeck Park, 6th Street Viaduct parklands, and the Mission/Jesse area. Due to nutrients in the recycled water, flows for HPL replenishment will be conveyed to the shoreline wetlands where it will be treated before entering HPL, as described in Section 5.2. A process flow diagram for the recycled water source alternative is shown on Figure 3-9.

Due to chlorine present in the recycled water, the water must be dechlorinated before use at the ATF's bio-trickling filters. The most cost effective method for dechlorination is to use sodium bisulfite, which requires a chemical tank and metering pump to deliver the chemical.

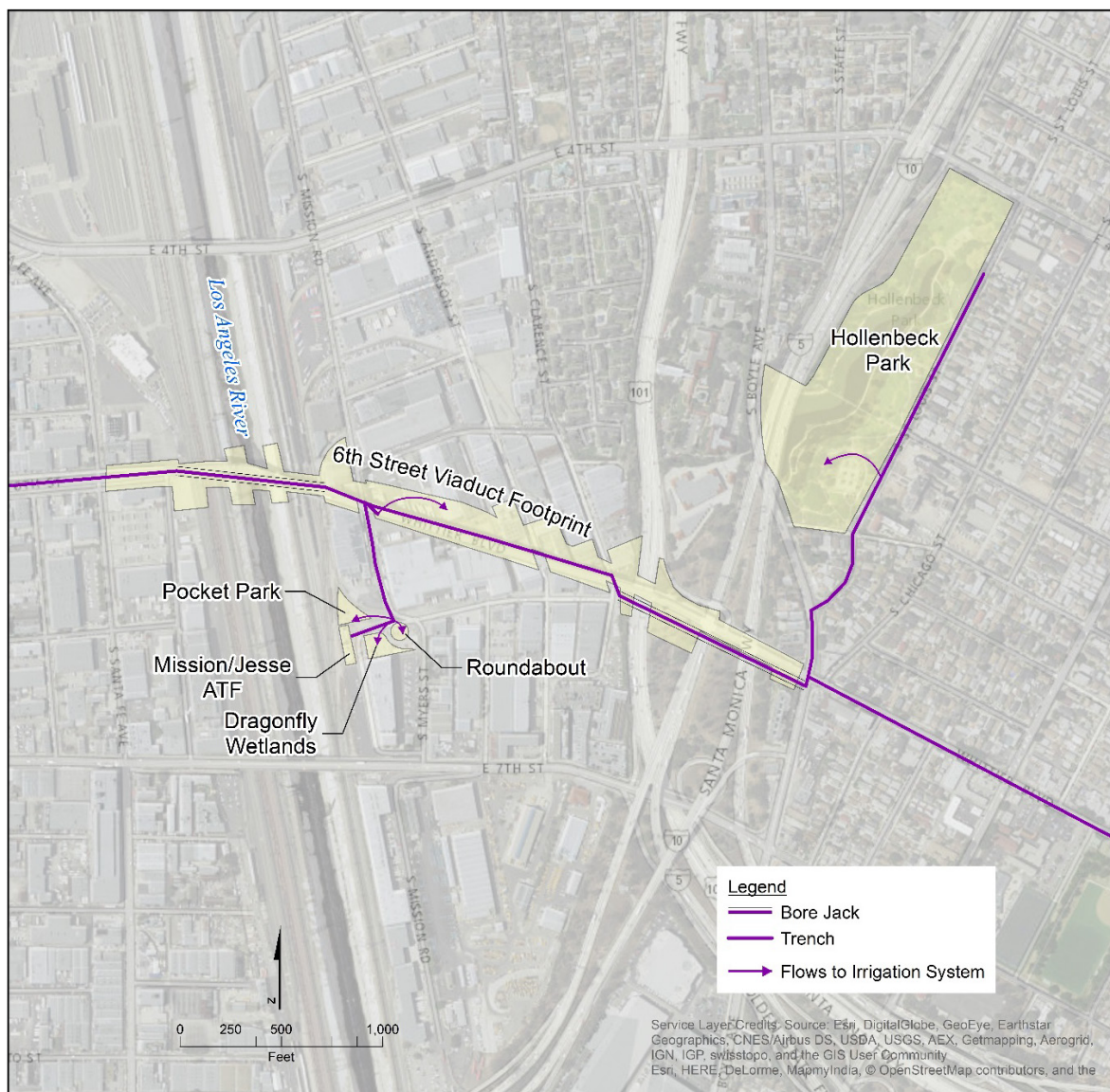

Figure 3-8. Conceptual Conveyance Alignment, Water Supply Alternative: LADWP Recycled Water
Hollenbeck Park Lake Rehabilitation and Stormwater Management

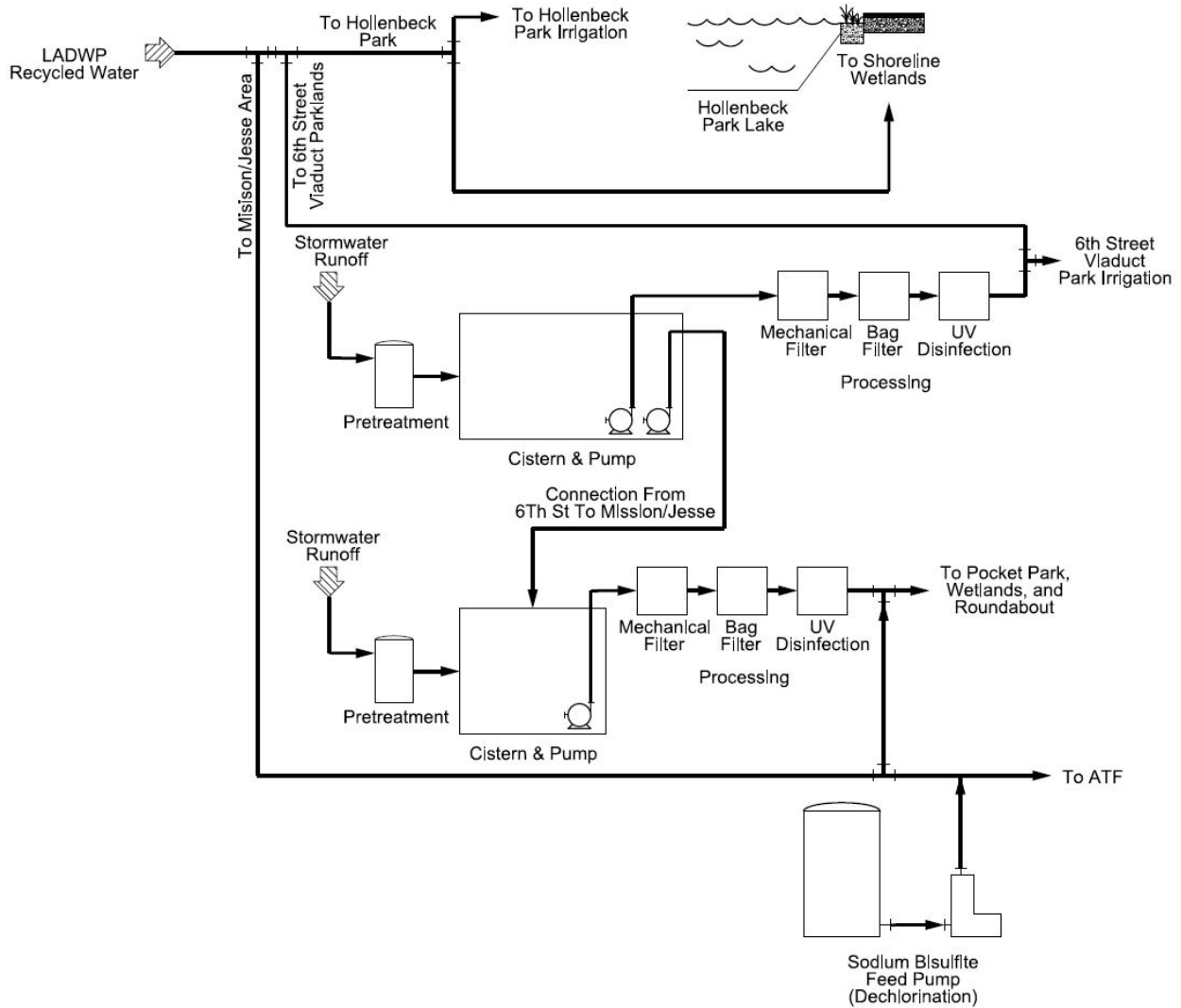

Figure 3-9. Process Flow Diagram, Water Supply Alternative: LADWP Recycled Water
 Hollenbeck Park Lake Rehabilitation and Stormwater Management

3.4.3 Permitting

Table 3-5 includes preliminary identification of potential permits or regulatory approvals that may be required for the LADWP recycled water supply alternative.

Table 3-5. Preliminary Summary of Environmental Permits/Approvals for LADWP Recycled Water Source Alternative
 Hollenbeck Park Lake Rehabilitation and Stormwater Management

Activity	Permit/Approval	Acquisition Schedule
Change in the point of discharge, place of use, or purpose of use of treated wastewater. Applicable for applicants seeking grant funds for water pollution control and water recycling projects.	Section 1211 of the Water Code requires that before making a change in the point of discharge, place of use, or purpose of use of treated wastewater, the owner of the treatment plant must seek approval from the Division of Water Rights, which is accomplished by filing a Petition for Change. To determine whether it is necessary to file a petition with the Division of Water Rights, an agency may discuss a proposed water pollution control or water recycling project with staff in the Division of Water Rights. Based on this discussion, the Division of Water Rights will issue a letter of determination whether no further action is required or a petition must be filed.	Petition for Change: 6 – 9 months

Table 3-5. Preliminary Summary of Environmental Permits/Approvals for LADWP Recycled Water Source Alternative Hollenbeck Park Lake Rehabilitation and Stormwater Management

Activity	Permit/Approval	Acquisition Schedule
Discharge of recycled water to lake and park irrigation	<p>State</p> <ul style="list-style-type: none"> - General WDR for Recycled Water Use, WARCB Order WQ 2014-0090-DWQ-CORRECTED (Adopted June 3, 2014). Permit application includes submittal of an NOI to the Los Angeles RWQCB consisting of a Water Recycling Program technical report and Title 22 Engineering Report approval letter from CDPH (see below).^a - Title 22 Engineering Report approval letter from CDPH <p>Local</p> <ul style="list-style-type: none"> - Title 22 Engineering Report approval letter from LACDPH 	<p>State</p> <ul style="list-style-type: none"> - General WDR for Recycled Water Use: 4 – 6 months - Title 22 Engineering Report approval: 4 – 6 months <p>Local</p> <ul style="list-style-type: none"> - Title 22 Engineering Report approval: 4 – 6 months
Project undertaking as a whole (i.e. pump station, recycled water conveyance pipeline, chemical storage/feed, storm drain diversion)	<ul style="list-style-type: none"> - CEQA environmental review and public disclosure. An Initial Study/Mitigated Negative Declaration (IS/MND would likely be adequate^b). - NPDES General Permit for storm water discharges associated with construction activities. Applicable to construction activities consisting of one acre or more of disturbance and includes developing a Storm Water Pollution Prevention Plan and implementing best management practices and conducting inspection during construction. An NOI must be submitted to the SWRCB to obtain coverage under the General Permit. 	<ul style="list-style-type: none"> - CEQA (IS/MND): 6 – 9 months - SWRCB coverage under General Permit: 1 – 2 months

Notes:

^a The SWRCB is currently circulating a Draft Order (Order WQ 2016-00XX-DDW) to replace General Order WQ 2014-0090-DWQ-CORRECTED.

^b Issuance of State Permits (unless an already authorized general order) typically require CEQA review.

3.4.4 Cost

Collaboration and potential cost sharing between the LADWP and LASAN for the construction of the recycled water conveyance pipeline along the 6th Street Viaduct right-of-way will meet the goals of the Project while providing an opportunity for LADWP to deliver recycled water to the Boyle Heights community. Financial responsibility and opportunities for cost sharing of the recycled water pipeline have not been determined at this time. It is assumed that LADWP will construct this pipeline from San Pedro Street to Clarence Street, and the Project will pay for the remaining portion of the pipeline to Hollenbeck Park.

To provide a cost comparison of water supply alternatives, a construction cost estimate was prepared to show costs specific to the LADWP recycled water supply alternative. The following components were included in this estimate, including markup:

- Conveyance of 16-inch pipe from Clarence Street/Jesse Street to Hollenbeck Park including bore and jack sections
- Sodium bisulfite chemical tank and metering pump for dechlorination

The estimated cost for only the LADWP recycled water supply alternative is \$1,137,371. The basis of design for all cost estimates is presented in Section 6.1.

3.5 Alternative 3: Sewer Mining

3.5.1 Flow Analysis

Sewer mining is the extraction of wastewater directly from the collection system and treating it at a wastewater treatment facility and then reusing the reclaimed water onsite for landscape irrigation and other beneficial purposes. There must be adequate average non-stormwater wastewater flow to meet the recycled water demand as well as to allow the return of treatment residuals to the sewer system.

The Mission/Jesse area was determined to be the preferred treatment location for the sewer mining alternative. The ATF is purposefully placed near the transition 96-inch Northeastern Interceptor Sewer; therefore the area has sufficient wastewater flows to supply the treatment facility and return residuals. The industrial setting and nearby railroads reduce noise concerns and proximity to the ATF provides possibilities for odor control. There is available space near Mission Road and Jesse Street at the Dragonfly Wetlands or adjacent to the pocket park.

Hollenbeck Park was also considered for sewer mining, however smaller local sewer lines convey smaller wastewater flows and is not preferred when discharging the residuals back to the system. Space constraints at the park as well as noise and odor concerns in the surrounding neighborhood also make Hollenbeck Park a less favorable location.

3.5.2 Conceptual Design

For residential irrigation and other non-restricted irrigation reuse schemes (i.e. irrigation of food crops, parks and playgrounds, school yards), Title 22, *California Code of Regulations* (CCR) Division 4, Chapter 3 requires at least disinfected recycled water that shall at all times be adequately oxidized, filtered, and disinfected and shall meet the following limitations:

1. Turbidity of the filtered effluent (if treated through conventional processes) shall not exceed any of the following:
 - (a) Average of 2 nephelometric turbidity units (NTUs) within any calendar day
 - (b) 5 NTUs more than 5 percent of the time in any calendar day
 - (c) 10 NTUs at any time
2. Disinfected wastewater shall meet the following:
 - (a) The median concentration of total coliform bacteria in the disinfected effluent shall not exceed a most probable number of 2.2 per 100 milliliters (mL) utilizing the bacteriological results of the last 7 days for which analysis has been completed.
 - (b) The number of total coliform organisms shall not exceed a most probable number of 23 total coliform bacteria per 100 mL in more than one sample in any calendar month.
 - (c) No total coliform sample shall exceed a most probable number of 240 total coliform bacteria per 100 mL.
 - (d) When a chlorine disinfection process is utilized followed by filtration, a CT (the product of total chlorine residual and modal contact time measured at the same point) value of not less than 450 milligram-minutes per liter at all times with a modal contact time of at least 90 minutes, based on peak non-stormwater design flow, shall be provided.
3. The pH of the discharge shall be within the range of 6.0 to 9.0 pH units at all times.

In order to produce disinfected recycled water per CCR, at minimum, wastewater should be treated through secondary treatment (biological treatment) followed by filtration and disinfection. Membrane bioreactors (MBRs) combine secondary treatment with membrane filtration, which minimize the space

requirements while consistently producing a high quality effluent. MBR systems are fully automated, minimizing labor required to operate and maintain MBR facilities. Figure 3-10 shows a simplified process schematic of an MBR system coupled with ultraviolet (UV) disinfection to produce disinfected tertiary recycled water.

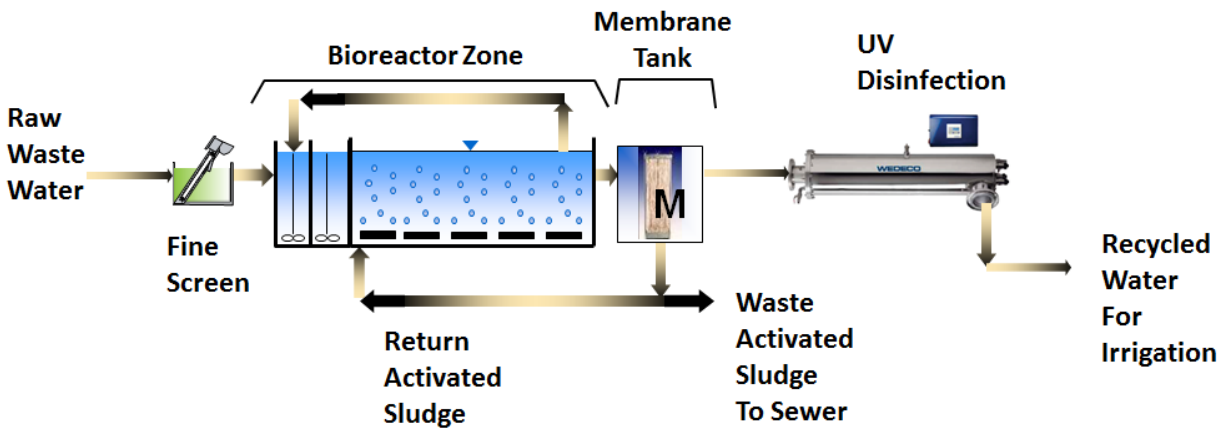

Figure 3-10. Simplified Process Schematic of MBR System
Hollenbeck Park Lake Rehabilitation and Stormwater Management

The MBR example on Figure 3-9 was configured in anoxic and aerobic mode to achieve combined BOD and nitrogen removal. It can be customized in various ways to meet specific water quality requirements. Based on flow and treatment objectives, two packaged MBR systems each with a peak treatment capacity of 60,000 gallons per day and a closed vessel UV disinfection system with two banks each, with a treatment capacity of up to 110,000 gallons per day are recommended. This arrangement will meet water quality objectives and satisfy reliability and redundancy requirements of Title 22 CCR. Each packaged MBR system comes with a pre-fabricated container (10 feet wide, 40 feet long, and 10 feet deep) housing treatment equipment. An example of a packaged MBR unit is shown on Figure 3-11.

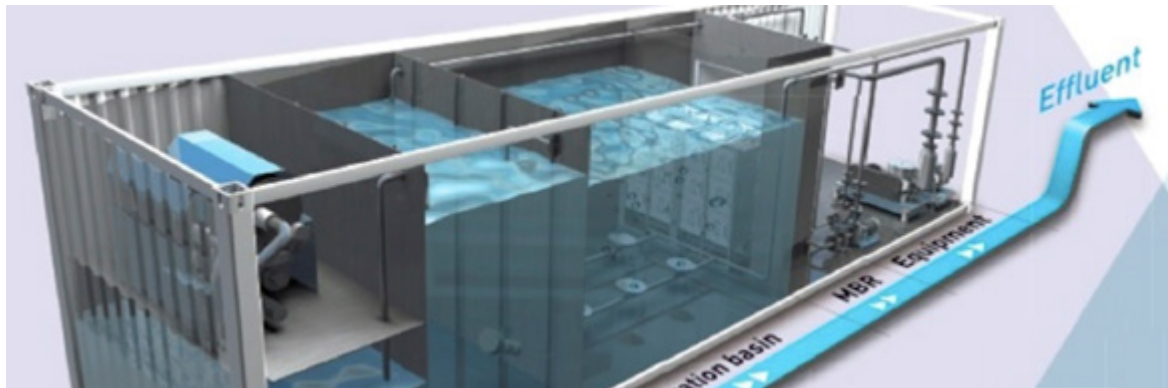

Figure 3-11. Example of a Packaged (Containerized) MBR System
Hollenbeck Park Lake Rehabilitation and Stormwater Management
(Courtesy of GE-Process and Water Technologies)

MBR systems require fine screening of raw wastewater to protect membrane fibers against abrasion, tear and cut. A clean in place (CIP) system is also required to periodically clean the membranes to restore membrane productivity. Sodium hypochlorite and citric acid are the most commonly used cleaning chemicals in MBR systems. CIP can be initiated automatically or manually. To minimize odor generated from the fine screens, an odor collection and treatment system should be incorporated into the facility design. Noise control may be necessary for the blowers and permeate pumps, if they are not housed in a building. A complete system including fine screens, packaged MBR units and all ancillary equipment and CIP system, chemical storage and feed system, UV system, and electrical rooms odor and noise control will require approximately 2,500 square feet of space to install (50 feet by 50 feet). The dimension can be adjusted to fit the Project site.

Capital and operation and maintenance (O&M) costs of the system are dependent on capacity of the system, characteristics of the raw wastewater, amount of wastewater treated, treatment (equipment) unit processes selected and effluent water quality requirements. The treatment system requires routine maintenance twice a week for a total of 6-8 hours per week by a certified wastewater treatment plant operator. Since MBR is a biological system, continuous operation is required to avoid starving microorganisms and ensure performance of the system.

During wet weather where recycled water demand is low or non-existing, the following considerations should be taken:

- The MBR system should continue to operate with lower flows to maintain microbiological activity and without operating the UV system. MBR treated water will be discharged into the sewer system or other approved discharge locations.
- If recycled water storage is provided, the produced recycled water during wet weather may be stored in a storage tank. Providing a storage tank will increase space requirement but can provide flexibility for plant operation and possibly reducing size of the treatment unit processes.

At a regional level, decentralized treatment may not be preferred by the wastewater agency due to the downstream impacts. After treatment, solids are returned to the sewer system thereby increasing the solids concentration in the collection system, impacting the conveyance and downstream treatment processes. However, for such a small system, the downstream impacts to treatment processes are expected to be minimal.

Figure 3-12 shows the conceptual sewer mining location and conveyance layout for a 4-inch pipe. The proposed alignment follows Jesse Street to Clarence Street before reaching Hollenbeck Park. Two bore and jack segments will be needed to cross the US-101, I-10, and I-5 freeways utilizing the existing sewer and storm drain easement. An alternate conveyance alignment may be through the 6th Street Viaduct footprint. Figure 3-13 shows the process flow diagram for this alternative.

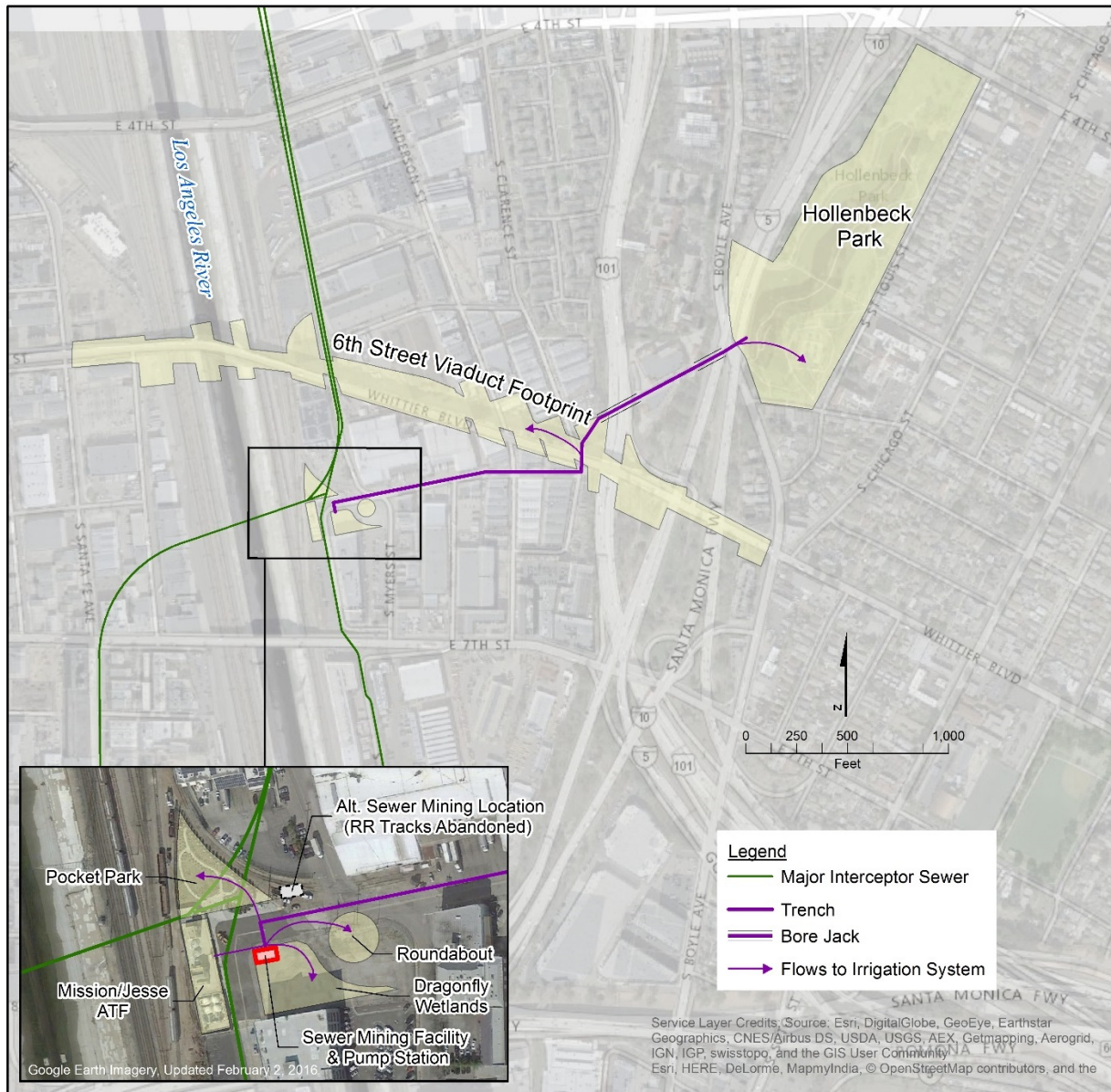

Figure 3-12. Conceptual Conveyance Alignment, Water Supply Alternative: Sewer Mining
 Hollenbeck Park Lake Rehabilitation and Stormwater Management

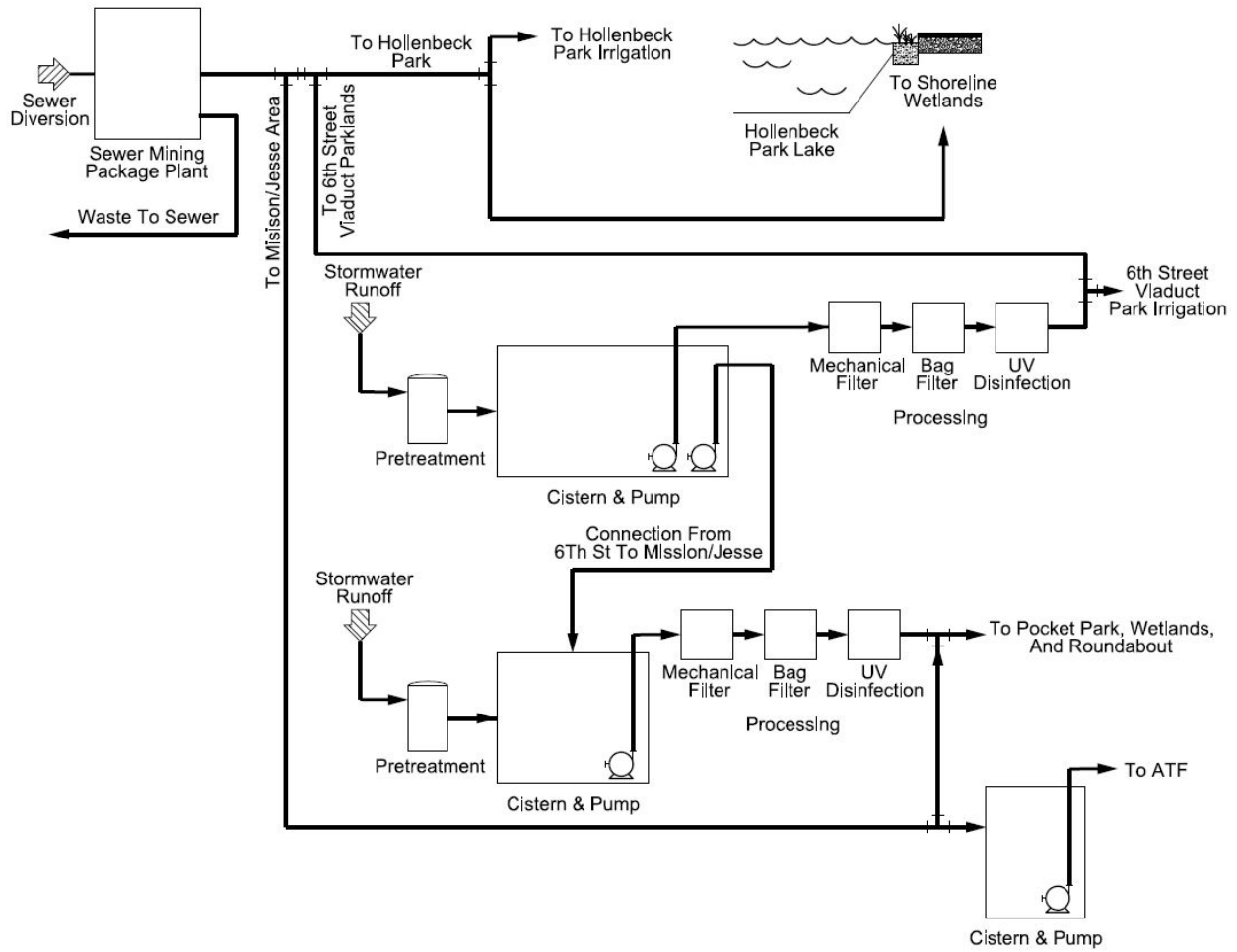

Figure 3-13. Process Flow Diagram, Water Supply Alternative: Sewer Mining
 Hollenbeck Park Lake Rehabilitation and Stormwater Management

3.5.3 Permitting

Table 3-6 includes preliminary identification of potential permits or regulatory approvals that may be required for the sewer mining water supply alternative.

Table 3-6. Preliminary Summary of Environmental Permits/Approvals for Sewer Mining Source Alternative
 Hollenbeck Park Lake Rehabilitation and Stormwater Management

Activity	Permit/Approval	Acquisition Schedule
Change in the point of discharge, place of use, or purpose of use of treated wastewater. Applicable for applicants seeking grant funds for water pollution control and water recycling projects.	Section 1211 of the Water Code requires that before making a change in the point of discharge, place of use, or purpose of use of treated wastewater, the owner of the treatment plant must seek approval from the Division of Water Rights, which is accomplished by filing a Petition for Change. To determine whether it is necessary to file a petition with the Division of Water Rights, an agency may discuss a proposed water pollution control or water recycling project with staff in the Division of Water Rights. Based on this discussion, the Water Rights will issue a letter of determination whether no further action is required or a petition must be filed.	Petition for Change: 6 – 9 months

Table 3-6. Preliminary Summary of Environmental Permits/Approvals for Sewer Mining Source Alternative
Hollenbeck Park Lake Rehabilitation and Stormwater Management

Activity	Permit/Approval	Acquisition Schedule
Discharge of Sewer Mining reclaimed water to lake and park irrigation, and use at ATF	State	State
	– Individual (site-specific) WDR and/or NPDES Permit from RWQCB Region 4	– Individual (site-specific) WDR and/or NPDES Permit for Recycled Water Use: 4 – 6 months
	– Title 22 Engineering Report approval letter from CDPH	– Title 22 Engineering Report approval: 4 – 6 months
	Local	Local
	– Title 22 Engineering Report approval letter from LACDPH	– Title 22 Engineering Report approval: 4 – 6 months
Project undertaking as a whole (i.e., pump station, membrane bioreactor, reclaimed water conveyance pipeline, chemical storage/feed, storm drain diversion)	– California Environmental Quality Act (CEQA) environmental review and public disclosure. An Initial Study/Mitigated Negative Declaration (IS/MND) would likely be adequate. ^a	– CEQA (IS/MND): 6 – 9 months
	– NPDES General Permit for storm water discharges associated with construction activities. Applicable to construction activities consisting of one acre or more of disturbance and includes developing a Storm Water Pollution Prevention Plan and implementing best management practices and conducting inspection during construction. An NOI must be submitted to the SWRCB to obtain coverage under the General Permit.	– SWRCB coverage under General Permit: 1 – 2 months

Notes:

^a Issuance of State Permits (unless an already authorized general order) typically requires CEQA review.

3.5.4 Cost

To provide a cost comparison of water supply alternatives, a construction cost estimate was prepared to show costs specific to the sewer mining water supply alternative. Construction costs were estimated for the project components unique to the sewer mining water supply alternative. The following components were included in this estimate, including markup:

- Sewer mining MBR package treatment plant
- Cistern and pump at Mission/Jesse intersection
- Conveyance of 4-inch ductile iron pipe including bore and jack sections

The estimated cost for only the sewer mining water supply alternative is \$7,463,174. The basis of design for all cost estimates is presented in Section 6.1.

3.6 Alternative 4: Non-stormwater and Stormwater Flow Diversion

3.6.1 Flow Analysis

Dry/Wet Weather Flow Diversion: As discussed in Section 2.3.2, approximately 13 AFY of non-stormwater flows bypass HPL in the underlying storm drain system shown on Figure 3-14. Although a dry weather flow study is needed to determine the actual flows, the estimated 13 AFY does not meet the annual water demand for the Project of 74.1 AFY but can be used to supplement another supply alternative. However, diverting and treating non-stormwater provides an opportunity to improve the overall quality of the watershed by treating the flows prior to discharge at the Los Angeles River.

Given the large 430-acre tributary area to the storm drain system, a significant amount of stormwater is available during a rain event. HPL already receives overflows during large storm events but flows from smaller (less than one inch) storm events currently bypass the lake. Therefore, to reduce pollutant loading in the watershed, a storm drain diversion is proposed to capture both dry weather flows and a portion of stormwater flows. The amount of flow captured during a storm is also limited to the rate at which the water can be pretreated and pumped through the wetland system described in Section 5.2.

Diversion of HPL Overflows: Overflows from HPL exit the lake through an LACFCD outlet structure at the southern end of HPL and are conveyed west along Jesse Street and south on Rio Street as shown on Figure 3-14. Given the proximity of this storm drain to the 6th Street Viaduct parklands and Mission/Jesse area, a storm drain diversion to capture HPL overflows to be stored at the 6th Street Viaduct and Mission/Jesse cisterns was considered. Water balance modeling efforts concluded that lake overflows result from large storm events and only occur one to five times per year. Climate change predications also indicate that future precipitation will be delivered by less frequent, higher intensity storms meaning future HPL overflows may reduce to only once or twice per year. Also, stormwater harvesting vendors advised against storing lake water in an underground cistern, as it would have a higher potential for fouling. Given the cost of diversion and additional storage, fouling potential, and infrequent capture events, diversion of HPL overflows were determined to be infeasible for the Project.

3.6.2 Conceptual Design

A storm drain diversion to capture non-stormwater flows and some storm flows will be constructed at the northern end of HPL as shown on Figure 3-14. Diverted flows will be pretreated and pumped to the lake directly or through the wetland system described in Section 5.3. Similar to the Los Angeles River Alternative, a new submersible pump will be placed in the existing wet well, adjacent to the existing pump used for HPL's fountains as shown on Figure 3-5. Water from HPL will then be pumped through the processing system before distribution to HPL's irrigation system. Since there is not enough non-stormwater flow to supply the Project in the dry months, this alternative must be combined with another source alternative.



Figure 3-14. Conceptual Conveyance Alignment, Water Supply Alternative: HPL Overflows
Hollenbeck Park Lake Rehabilitation and Stormwater Management

3.6.3 Permitting

Table 3-7 includes preliminary identification of potential permits or regulatory approvals that may be required for the dry/wet weather flow diversion alternative.

Table 3-7. Preliminary Summary of Environmental Permits/Approvals for Dry/Wet Weather Flow Diversion Alternative

Hollenbeck Park Lake Rehabilitation and Stormwater Management

Activity	Permit/Approval	Acquisition Schedule
Discharge of diverted storm water to lake and park irrigation	State	State
	<ul style="list-style-type: none"> – RWQCB Region 4: Discharge of diverted storm drain water for irrigation may be regulated under the City of Los Angeles MS4 Permit (Amended Order WQ 2015-0075) – CDPH and Approval of diverted storm drain water for irrigation. 	<ul style="list-style-type: none"> – Coordination between City of Los Angeles and RWQCB Region 4 to confirm use of diverted storm drain water for irrigation is covered under MS4 Permit. – CDPH review and approval: 4- 6 months
	Local	Local
	<ul style="list-style-type: none"> – LACDPH Review and Approval of diverted storm drain water for irrigation. Water quality must achieve California Maximum Contamination Levels and California Toxics Rule Standards. Spray irrigation must also achieve coliform and bacteria limits and comply with a variety of operational conditions (e.g. setbacks from drinking fountains and adjacent properties, scheduling, signage) 	<ul style="list-style-type: none"> – LACDPH review and approval: 4 – 6 months – LACFCD review and approval: 4 – 6 months
	LACFCD District for connection/diversion from Los Angeles County storm drain system	

Notes:

^a Issuance of State Permits (unless an already authorized general order) typically require CEQA review.

3.6.4 Costs

There are not enough available dry weather and stormwater flows to meet the annual demand of the Project. However, diversion of non-stormwater and stormwater flows can be combined with any of the other alternatives to help augment water supply needs. The additional construction cost of the storm drain diversion is estimated to be \$1,439,933.

3.7 Alternatives Analysis Summary

Four water supply alternatives were evaluated to replace the potable water for the Project. The following summarizes the main advantages and disadvantages of each alternative source:

1. Los Angeles River Water Supply Alternative (Construction Cost: \$2,508,726)

- Advantages:
 - Use of flows that would otherwise drain to ocean
 - Reduce pollutant loading in Los Angeles River by treatment in HPL
 - Sustainable source of water
- Disadvantages:
 - Extensive permitting process for river intake structure can take 2 years or longer
 - Treatment required prior to irrigation resulting in higher costs
 - Dependence on Los Angeles River Cooperation Committee to recommend the Project

2. LADWP Recycled Water Supply Alternative (Construction Cost: \$1,137,371) – Recommended Source

- Advantages:
 - Least expensive alternative
 - Reliable source of water

- Easier permitting process
 - Water quality meets LACDPH irrigation standards
 - Recycled water conveyance will be owned and maintained by LADWP
 - Minimizes City’s pumping, treatment, energy, and O&M needs
 - LADWP benefits by utilization of City easements for river, railroad, and freeway crossings to serve additional potential customers in Boyle Heights area
- Disadvantages:
- Dependent on LADWP agreement to install recycled water line along 6th Street
 - Recycled water must be dechlorinated prior to use at ATF

3. Sewer Mining Water Supply Alternative (Construction Cost: \$7,463,174)

- Advantages:
- Design of treatment processes provides water quality control
 - Local and reliable source of water
- Disadvantages:
- Highest capital and maintenance cost
 - Weekly O&M needs conducted by specialized staff
 - Decentralized treatment is not preferred for regional wastewater system

4. Non-Stormwater and Stormwater Diversion (Additional Construction Cost: \$1,439,933)

- Advantages:
- Capture of non-stormwater and stormwater flows improves overall water quality of watershed
 - Can be combined with other alternatives
- Disadvantages:
- Flows are inadequate to supply total Project demand

3.7.1 Recommendation

The LADWP recycled water supply alternative was found to be the most favorable alternative for replacing potable water based on lower capital cost, reduced O&M from LADWP pipeline ownership, and recycled water quality already meets irrigation standards. In addition, diversion of non-stormwater and stormwater flows for use at the lake is also recommended to improve the overall stormwater quality in the watershed, reduce pollutant loading at the Los Angeles River, and maximize the use of an available source of water to supplement the recycled water demand.

Monthly recycled water demand is estimated to make up 60 percent of the overall annual Project demand as shown in Table 3-8, with winter demands as low as 25 percent. Based on the conceptual sizing of the storm drain diversion and stormwater management facilities at 6th Street and the Mission/Jesse intersection, dry weather and storm drain flows is expected to supplement 40 percent of the overall project demand. Figure 3-15 shows the integration of the diversion with the recycled water supply. Implementation of the LADWP recycled water supply alternative and storm drain diversion with other Project recommendations is discussed in Section 5.

Table 3-8. Recycled Water Demand*Hollenbeck Park Lake Rehabilitation and Stormwater Management*

	January	February	March	April	May	June	July	August	September	October	November	December	Annual
	gal/ month	gal/ month	gal/ month	gal/ month	gal/ month	gal/ month	gal/ month	gal/ month	gal/ month	gal/ month	gal/ month	gal/ month	AFY
Hollenbeck Park Recycled Water Demand	-	-	-	67,430	673,879	1,090,459	1,656,580	1,794,897	1,051,177	678,527	451,319	-	22.9
6th Street Recycled Water Demand	29,469	22,627	91,379	223,201	372,793	454,513	468,249	458,231	305,457	221,496	82,753	11,811	8.4
Mission/Jesse Recycled Water Demand	284,396	279,822	313,739	349,303	387,518	393,884	405,858	404,907	361,723	359,252	310,042	242,365	12.6
Total Recycled Water Demand	313,865	302,449	405,118	639,934	1,434,190	1,938,856	2,530,687	2,658,035	1,718,357	1,259,275	844,114	254,176	43.9
Percentage of Total Demand	27	25	38	43	69	75	78	80	64	54	41	31	59

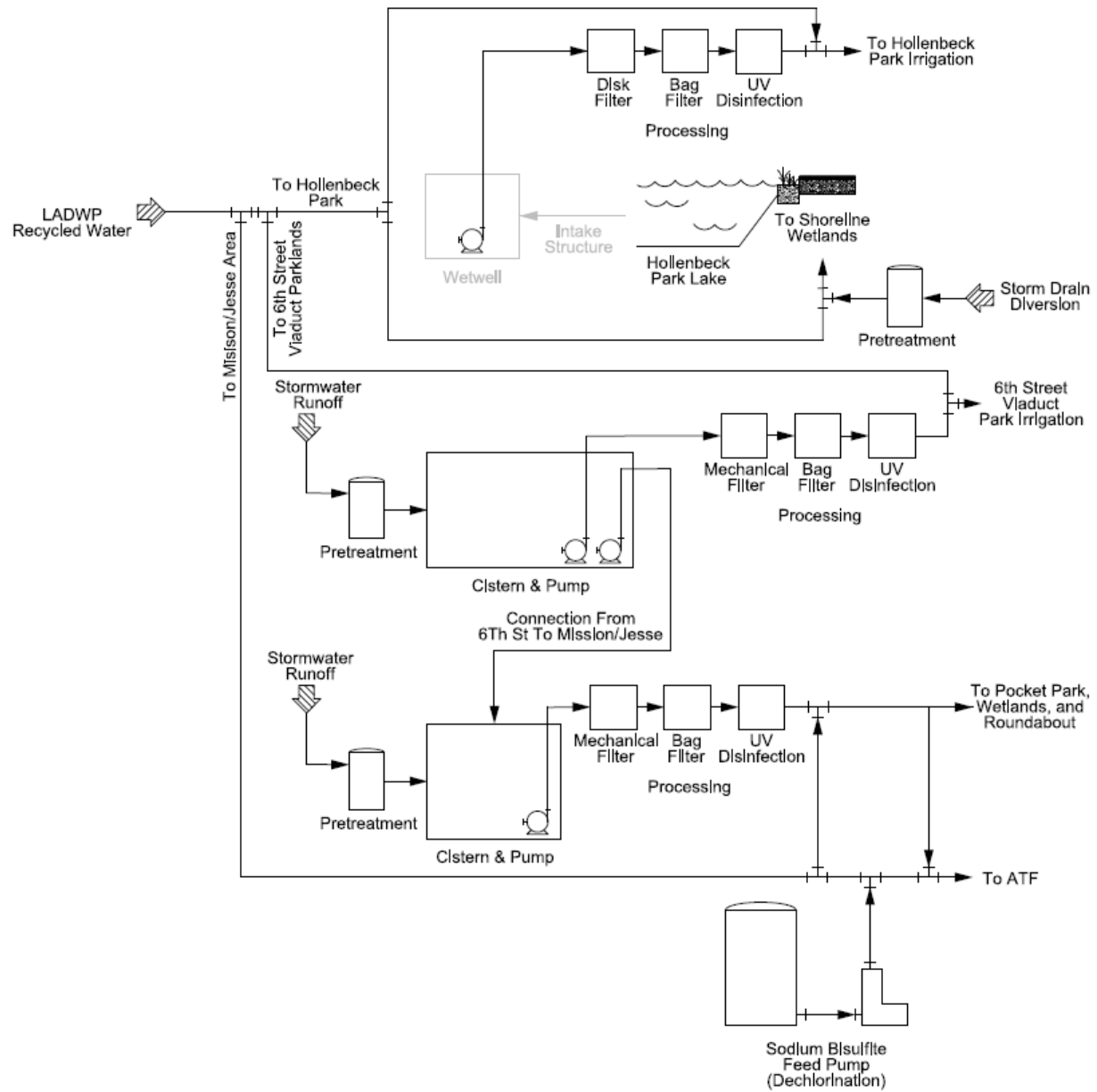

Figure 3-15. Process Flow Diagram of Proposed Water Supply at HPL
 Hollenbeck Park Lake Rehabilitation and Stormwater Management

Current Water Quality Improvements at HPL

Since water quality improvements can be implemented in a relatively short time frame and are independent of the downstream projects, an initial set of improvements is recommended to begin addressing water quality concerns at HPL. The following section summarizes current water quality improvements being implemented at HPL. Future improvements are described in Section 5 and outline recommendations to address long-term concerns for water supply, water conservation, lakeside erosion, and integration with the 6th Street Viaduct parklands and Mission/Jesse area.

HPL has a history of water quality concerns attributable to nutrient and sediment loading as well as site-specific factors. Given that two decades have passed since the operation of the treatment systems installed at HPL, with the exception of the fountain recirculation system, it is highly likely that sediment has deepened and that internal cycling of nitrogen and phosphorus from the sediments to the water column continues within HPL, thereby elevating algal populations and contributing to a deterioration in lake water quality through eutrophication and a decrease in dissolved oxygen (DO). The buildup of sediments and decaying organic matter also contributes to the depletion of DO within HPL's water column. Sufficient DO levels are required to sustain a stable aquatic ecosystem and allow for a variety of benthic organisms (e.g., ground and flat worms, snails, slugs, nymphs, etc.) to thrive on the bottom and add to the food chain present in HPL.

To improve HPL water quality and appearance, a lake rehabilitation system similar to the approaches currently being implemented at other City of Los Angeles lakes, such as Echo Park, Machado, and Reseda, is being considered. For long-term control of lake nutrients and algae, as well as to improve the park user experience, recommended current water quality improvements include floating wetland islands, an aeration system, and an alum injection system. These improvements are anticipated to improve clarity and quality of HPL water through the following processes:

- The floating wetland islands are expected to help control algae through competition for nutrients, enhanced settling of algal cells, and water column shading, and will assist with transformation and removal of nitrogen through denitrification.
- Aeration is anticipated to improve water clarity through reduction in algal populations, and assist with nitrogen transformation from organic and ammonia forms by nitrification, and to enhance decomposition of organic sediments, thereby reducing internal loading from HPL sediments.
- Alum injection will reduce phosphorus concentrations, thereby reducing algal populations and enhance solids settling.
- The existing recirculation system will integrate all of these nutrient removal and algal reduction processes by maintaining a short hydraulic residence time and assisting with the transport and distribution of alum throughout the lake, and through and around the root mat suspended from the floating wetland island.

The long-term rehabilitation of HPL is proposed to include the use of alternative sources of water to eliminate the need for potable water use in lake make-up water, the construction of shoreline constructed wetlands to remove nutrients from alternative water supply sources, dredging and removal of lake sediment, and liner renovation of HPL. Park landscaping enhancements are also proposed to reduce site erosion. These improvements will position HPL for long-term control of algae while conserving water supply. However, the implementation of these measures is expected to require time.

4.1 Floating Wetland Islands

4.1.1 Background

Floating wetland islands are a relatively new natural treatment technology that is increasingly used for improvement of water quality in lakes, particularly in an urban setting. The islands are buoyant materials, usually made of high-strength, UV-resistant plastic foam, with airtight cells inserted for buoyancy. The islands are typically planted with wetland species, which ultimately grow up and through the media. The plants produce large root mats that hang suspended in the water. Water taken up by the plants is treated as it passes through the root zone. Pollutants may be assimilated directly in the plant tissue, transformed as they come in contact with the microbial community that grows attached to the root and floating island matrix, or allowed to settle to the lake bottom either as plant tissue or through enhanced sedimentation within the quiescent proximity to the island.

A 2015 study conducted in Florida found a 32 percent reduction in nitrogen removal when introducing floating wetland islands to wastewater effluent (Vázquez-Burney et al., 2015). Recent literature reviews concluded that FWIs improve phosphorus removal by 2 to 55 percent and nitrogen removal by 12 to 42 percent relative to controls (Dodkins and Mendzil, 2014). Phosphorus concentration reductions were generally lower if island cover was low (<10 percent), hydraulic residence times were short during storm event throughput, or water column was anaerobic, which favored recycling of phosphorus. Nitrogen removal improves in the presence of FWIs, with enhanced denitrification in nitrate-rich stormwater attributable to low DO and increased organic carbon availability in the root zone below the FWIs when compared to a control pond without FWIs. For the purpose of performance estimation, a median concentration reduction range of 10 percent for phosphorus and 20 percent for nitrogen is a conservative estimate for HPL FWIs, based upon the proposed cover estimate and aerobic recirculated water column. This reduction is in addition to the concentration reductions anticipated through aeration and other enhancements.

4.1.2 Application

Eight FWIs are proposed as a method of improving lake water quality. Each FWI will be comprised of five island mats totaling approximately 400 square feet (each mat will be approximately 8 feet by 10 feet in area). The total FWI area will equal 3,200 square feet, or 1.8 percent of the total lake area. An additional 2,640 square feet “area of influence” is projected to occur with areas enclosed by the FWIs, as well as adjacent to the perimeter of the FWI. With the addition of this area, the proposed full set of FWIs is projected to cover 3.1 percent of HPL area. At this stage in the development of floating wetlands as a treatment technology, no firm guidelines are available for relative sizing. Implemented islands have ranged from 1 percent to 100 percent. Typically, greater wetland island cover equates with more water quality benefits, but cost and impact to appearance limit the number and area of islands for recreational urban lakes. The pumped movement of water through Hollenbeck Park Lake helps enhance and expand the area of FWI influence. Also, the presence of aeration was considered to be a positive factor in improving floating wetland island performance (Dodkins and Mendzil, 2014). As a design, the approach to FWI placement for HPL has been to achieve a relatively even distribution of the FWIs across the lake.

As an initial step in the feasibility study and rehabilitation of HPL, only five floating wetland islands were installed in HPL in June 2015 as shown on Figure 4-5. This was intended to initiate a process of rehabilitation while allowing operational and maintenance experience to be gained at this location. Three additional FWIs are proposed to provide additional treatment to improve lake water quality as shown on Figure 4-5.

The proposed aeration system will enhance the treatment process of the FWIs, as well as the recirculation through the fountains. The aeration will allow nitrogen oxidized by the aeration system to be denitrified by FWIs, and for reduced nitrogen compounds shed by the FWIs and mobilizing from lake sediments to be oxidized. The aeration positions will complement the general wind-related movement of water and increase oxygen supply to the likely anaerobic lake sediments.

Each FWI is configured in a triangle or “chevron” shape as shown on Figure 4-1. The purpose of this configuration is to maximize the edge-to-area ratio of the island while creating an opportunity for quiescent conditions to form within the islands. Water moving in and out of this “area of influence” encounters quiescent conditions on a transient basis. This incrementally enhances sedimentation and provides a slightly longer time for treatment to occur relative to water moving outside of the island in the main body of HPL.

The alignment of the mats within the FWI is maintained by tensioning cables that run through each island in a polyvinyl chloride (PVC) guide, pre-installed by the manufacturers, and by a cable extending around the perimeter. Each island is anchored by tethering a 200-pound pyramid marine anchor on each apex of the triangle.

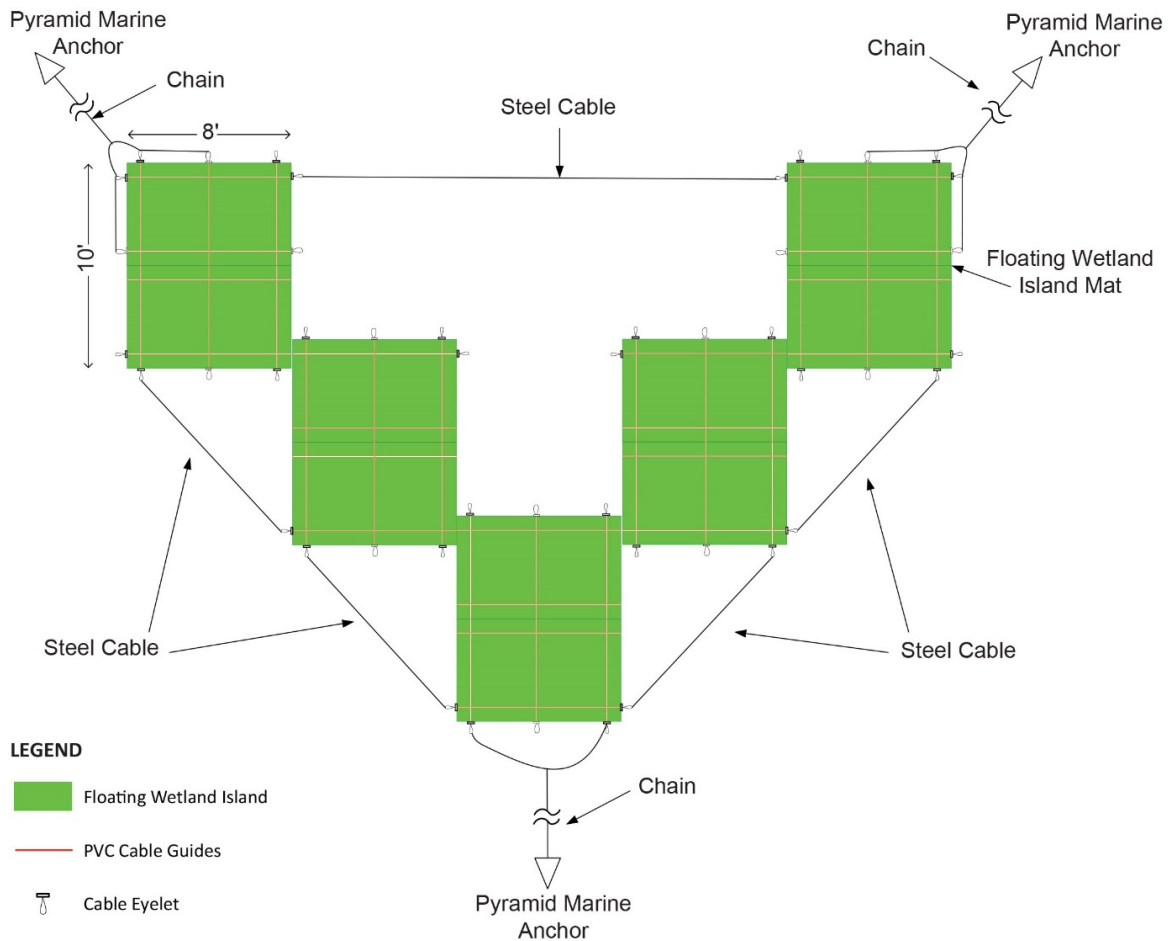

Note: Islands to be constructed from Biohaven® Floating Islands, with attachment and cable routing as shown.

WT0612151029RDD 05/13/16

Figure 4-1. Typical Floating Wetland Island Configuration
Hollenbeck Park Lake Rehabilitation and Stormwater Management

During the initial installation, the FWIs were planted in two distinct zones, with a 2-foot-wide zone around the perimeter covered with sod, and an interior zone planted with emergent wetland plant species. The sod zone was intended to create an area where wildlife may rest without damaging wetland plants. Observations indicated that more robust protective fencing would be needed to exclude waterfowl. The refurbishment of the FWIs and the installation of new FWIs is proposed to install wetland plants to the edge of each mat and include wildlife exclusion fencing around the perimeter of each island. The wetland species are designed to include a composite community of plant species frequently planted as part of natural restoration projects as well as ornamental planting projects. Taller species are planted in the interior. With time, the vegetation on each mat can be expected to coalesce into a dense mixture of plants.

The five existing FWIs will be replanted with the species found to be most resistant to the waterfowl grazing, as described recently in a technical memorandum (CH2M, 2016). Three new floating wetland islands will be installed, one at the most northern end, and two at the southern end. Each island will be outfitted with a vertical 2-foot fence, designed to prevent waterfowl from accessing the islands. The fence will be constructed of metal and attached with metal cables to the FWI substrate.

Plants and materials will be supplied from one or more of the same plant suppliers from the initial island installation: Floating Islands West LLC for the island substrate, and three nurseries (Southwest Wetland Plants for the plant propagules).

4.1.3 Cost

The materials and effort and associated costs for the three additional FWIs is estimated to be \$68,600.

4.2 Aeration

4.2.1 Background

The aeration system with bio-augmentation will enhance the natural systems of HPL through increasing the DO level throughout the water column. Bio-augmentation will be added 30 to 60 days after the initial turn-on of the diffuser system. The bio will cause the breakdown of the organics releasing the water held in the muck. Muck depth will diminish over time as the muck compresses. The higher DO levels will allow a variety of benthic organisms to thrive on the bottom and add to the food chain present in HPL. Overall, HPL should respond with clearer water, more aquatic life, and a stable ecosystem.

4.2.2 Application

The aeration system proposed for application is the CleanFlo laminar flow aeration. The process will circulate water so that oxygen is made available to all depths of water to expedite decomposition of organic material and removal of organic and ammonia-nitrogen. Safe bio-augmentation compounds will be applied to facilitate decomposition of sediment. The layout within HPL for the aeration system is shown on Figure 4-5 with squares represent the diffusers. A compressor cabinet will be constructed in the fenced compound under the freeway overpass.

The diffusers will be located at least 10 feet from the fountains to avoid any cavitation problems. The diffusers will also be placed to avoid the floating islands. Floating islands disrupt the laminar flow on the surface of the water and reduce treatment efficiency. The diffusers should be placed between the islands as much as practical.

The system will include a set of eight 12-inch micro-porous ceramic diffusers with two 1.5-hp compressors and brass check valves to insure longevity. A micro-porous diffuser is shown on Figure 4-2. A float is optional and not required on most installations. The compressor will be housed in a durable fiberglass outdoor cabinet with a sound reduction lining, cooling blower, filters and pressure relief valve. A total of 5,350 feet of self-sinking hose will be used to connect the compressor to the diffusers and insure the hose stays in place at the bottom of HPL. The system is complete with all cables, floats, clamps, splices, and fittings. Electrical power will be drawn from the electrical supply at the compressor site.



Figure 4-2. Typical Diffuser
Hollenbeck Park Lake Rehabilitation and Stormwater Management
 Source: CLEAN-FLO International, LLC.

4.2.3 Cost

The Clean-Flo aeration system will be procured from the Allied Group, Inc. The following system components are included:

- Cabinet for compressor
- Two 1.5-hp compressors
- Eight 12-inch micro-porous diffusers
- 5,350 feet of self-sinking hose for installation
- Stainless steel clamps and miscellaneous hardware

The installation will be performed by the Allied Group, Inc. Allied Group, Inc. will also provide one year of follow-up maintenance and bio-augmentation. An overview training session for maintenance of the aeration system will be provided.

The pricing for the installation and 1-year follow-up by the Allied Group, Inc. is estimated to be \$19,784. The price includes travel to and from Los Angeles, as well as all maintenance and bio-augmentation for 2016. A 10 percent contingency of \$1,978 is allowed to ensure sufficient resources and to expedite installation. Any electrical system modifications required are not included in this cost. An allowance for \$3,000 is included for electrical site work. Installation of air diffuser hoses will require subgrade placement and entry into HPL. A placeholder allowance of \$5,000 is included. The total cost estimate is rounded to \$30,000.

4.3 Chemical Feed System Retrofit

4.3.1 Background

Aluminum sulfate (alum) has long been used to improve water quality through solids flocculation and coagulation, followed by enhanced sedimentation. The basic concept is similar to that applied to drinking water treatment, where alum is dosed at a concentration large enough to form heavy flocs that sink to HPL bottom, leaving the surface layer clear. This method has a mixed record of success in lake systems, primarily due to chemical cost, specialized equipment to mix and create floc, and the need to remove settled floc over time.

However, an alternative dosing concept has been proven effective in shallow lakes that involves ultra-low doses of alum that do not form floc. Ultra-low alum feed systems are designed to bind phosphate without producing settled floc that would require periodic removal. Thus, the resulting decrease in phosphorus from the ultra-low alum dosing would have a cumulative effect of suppressing algae growth.

This approach is proven to restrict algae growth in shallow urban lakes. Installation of microfloc alum systems at two New Jersey lakes found a 50 percent reduction in chlorophyll-a and total phosphorous as well as a significant increase in water clarity. A case study was performed in 2009 for the microfloc alum injection system installed at Newman Lake in Washington. The study found that the treatment resulted in a 29 percent reduction in phosphorous, a 62 percent reduction in chlorophyll-a, and increased water visibility of 0.7 meters. The study also found the treatment had no significant impacts to the zooplankton population (Moore et al., 2009).

Potential adverse effects of using alum were evaluated in a 2005 case study at two lakes in Minnesota. Potential for aluminum toxicity is dependent on dose, pH, and inflow alkalinity. The study indicates that there is little risk to aquatic life from alum doses up to 8 mg/L. While adverse impacts may occur with alum floc accumulation, these impacts from floc accumulation are avoided by using the ultra-low alum dosing method (Osgood, 2012).

As a continuous, or seasonal, dosing system the resulting aluminum concentration should be well below published toxicity thresholds. U.S. Environmental Protection Agency guidelines indicate that the chronic toxicity threshold should be 87 µg Al/L when the pH is between 6.5 and 9.0. Application of water effect ratios, based on alkalinity, pH, and dissolved organic carbon, would likely raise chronic toxicity threshold above 100 µg Al/L. For HPL, this aluminum concentration or lower values would not lead to floc formation. Conceptually, the application of alum to the lake affords the potential for precise control of lake phosphorus concentration. Because of the inherent effort to maintain the dosing system and cost of repeated applications, this approach is considered to be preliminary for this conceptual plan, and only to be implemented after the installation and observation of the performance of the shoreline wetlands, floating wetland islands and aeration/recirculation system.

4.3.2 Application

Using the existing storage tank and re-equipping the system with a new metering pump, alum would be injected into the recirculation system, mixed under pumped transit to HPL, where it is discharged through the three site fountains and mixed with HPL water.

CH2M HILL Engineers, Inc. (CH2M) developed an alum dosing method based on investigations and insight into lake phosphorus dynamics. Using simple metering pumps and air diffusers, alum will be dissolved into HPL in small concentrations. Empirical data has shown that total phosphorus of 200 micrograms per liter can decrease to 70 micrograms per liter in a short amount of time. Secchi disk (visual) depths may increase from 30 to 90 centimeters.

For design purposes, a target dose concentration of 100 µg Al/L is proposed. To simplify design, there will be no flow proportioning. Dosing will be constant to target the Al concentration of 100 µg Al/L. Dosing rates may be increased or decreased per operational experience.

For HPL, the existing treatment system already includes alum storage and chemical dosing. To apply ultra-low alum dosing to this shallow lake, the same chemical storage and dosing system can be used. The pressure sand filters would not be needed because the treatment technology recommended now is not designed to form floc for removal but rather to sequester phosphate within HPL sediments. To achieve the design dose of 100 µg Al/L, at 750 gal/month recirculation rate (5-day turnover), approximately 1 pound per day of liquid alum would be needed.

Due to the viscosity of liquid alum, it needs to be dispersed into solution. One way to do this is by introducing the solution within the middle of an aeration diffuser's bubble stream. It should be metered in slowly to avoid local flow formation. Since an aeration system is being planned for HPL, it is convenient to dose the ultra-low level of alum in this fashion.

Coupled with the ultra-low alum injection system, the three existing fountains will be utilized to provide lake water recirculation and additional oxygenation. The fountain recirculation improves distribution and mixing of alum-injected lake water while also controlling algal growth and increasing HPL's DO. The increase in the DO concentration of the water column will offset the depletion of DO from HPL's buildup of decomposing organic matter in the sediments. The process flow diagram for the chemical feed system retrofit is shown on Figure 4-3. A plan view of the chemical feed system is shown on Figure 4-4.

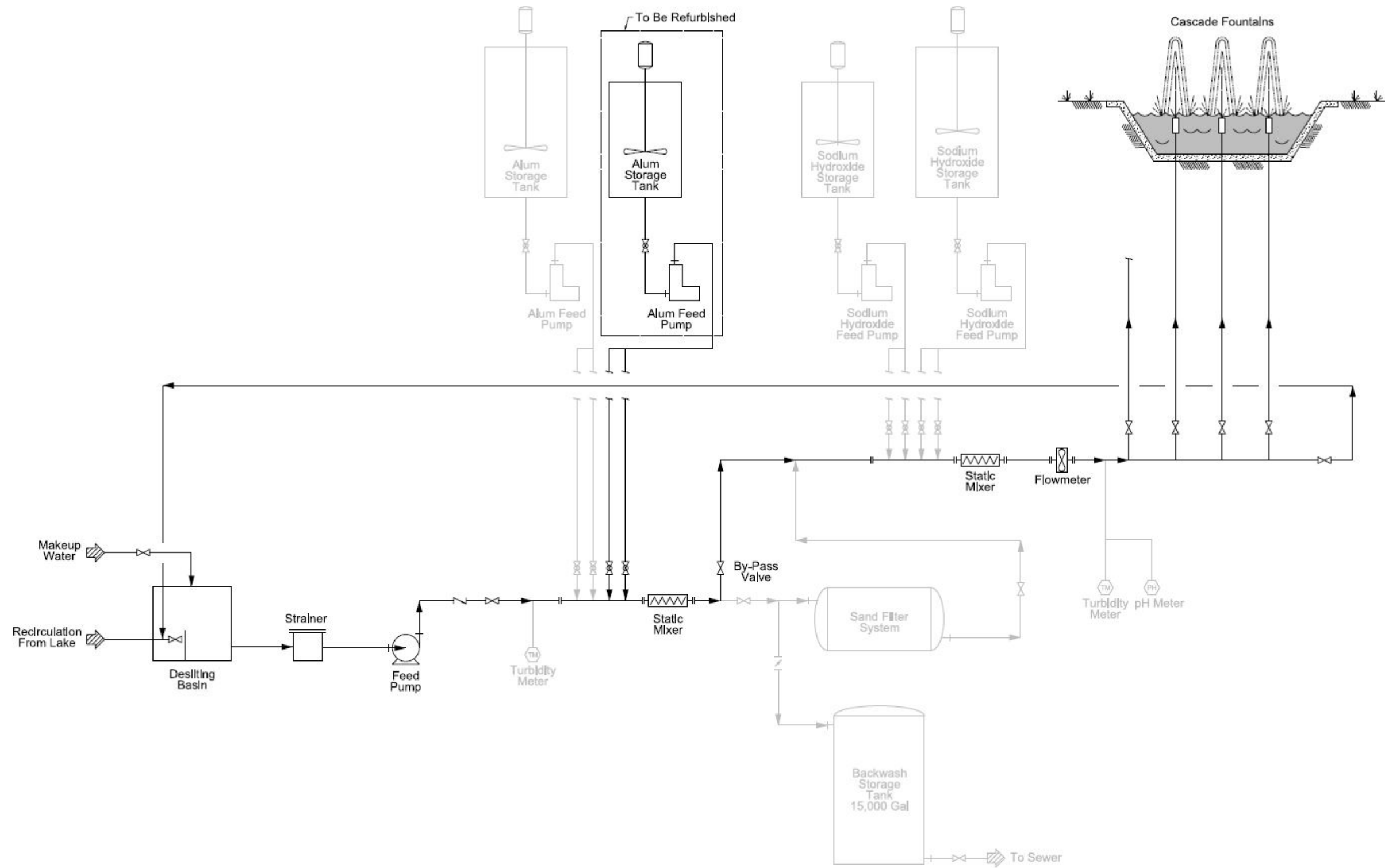

Figure 4-3. Process Flow Diagram for Chemical Feed System Retrofit
Hollenbeck Park Lake Rehabilitation and Stormwater Management

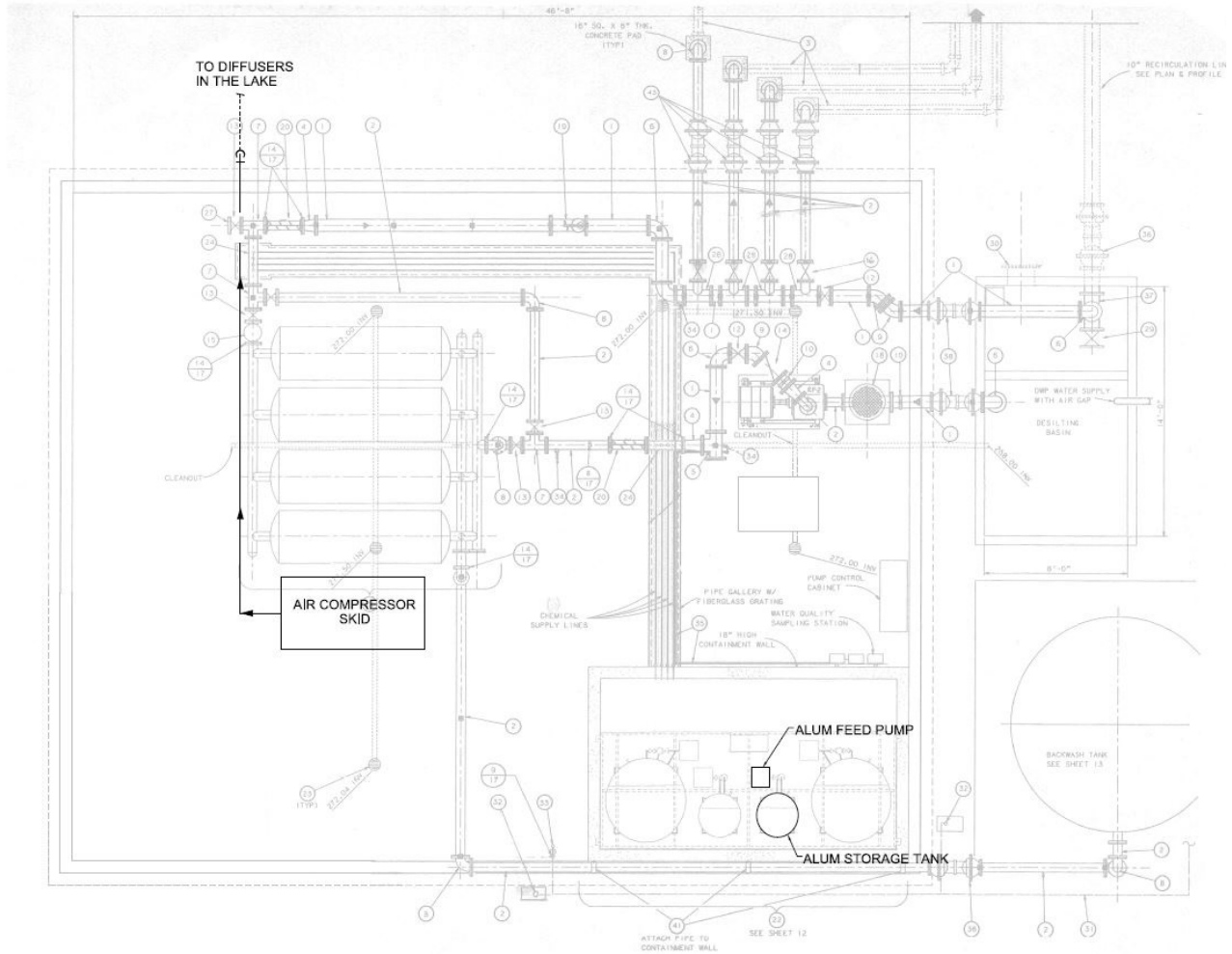

Figure 4-4. Chemical Feed System Equipment Layout
 Hollenbeck Park Lake Rehabilitation and Stormwater Management

4.3.3 Cost

Alum injection refurbishment will require purchase and installation of the following:

- 100-gallon storage tank
- Metering pump system

Given the concept of refurbishing existing systems, the work necessary is relatively straightforward. Based on discussion with suppliers, an estimate of \$10,000 is proposed for replacing the tank and to refurbish the existing pump. Dose optimization costs will require initial and follow-up water quality testing to measure phosphorus and aluminum in HPL and recirculation water, as well as general lake response. For initial optimization dosing, weekly sampling and laboratory analysis is proposed for a period of one month. A budget of \$10,000 is recommended for the initial four-week optimization period. The total cost is estimated to be \$20,000.

LEGEND

 Existing Floating Wetland Island

 New Floating Wetland Island

 Existing Fountain

 Aerator

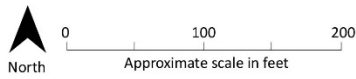
 North
0 100 200
Approximate scale in feet

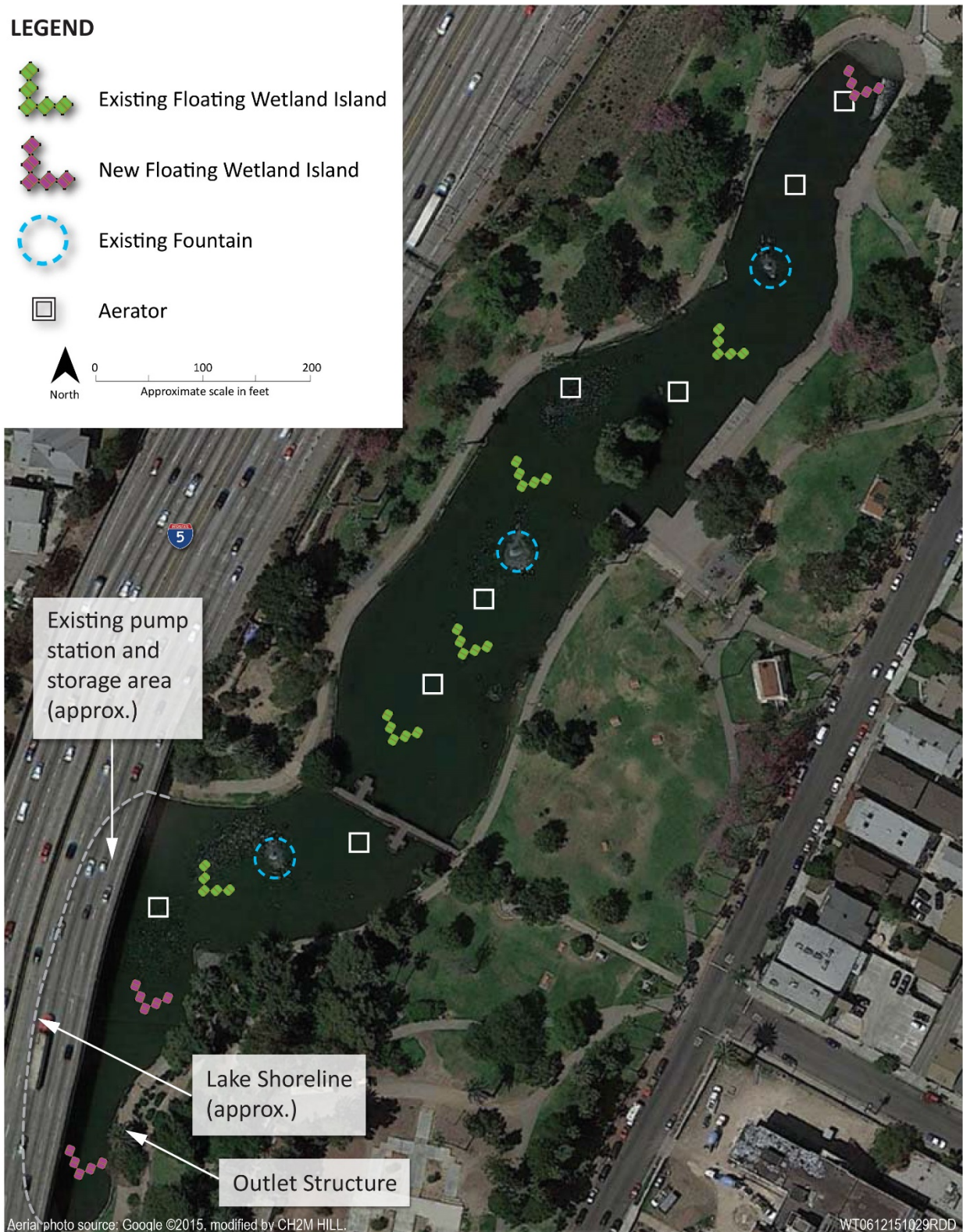

Aerial photo source: Google ©2015, modified by CH2M HILL.

WT0612151029RDD

Note: Island position to be adjusted during initial placement.

**Figure 4-5. Location of Current Water Quality Improvements
Hollenbeck Park Lake Rehabilitation and Stormwater Management**

Future Long-Term Improvements

An initial set of improvements to begin addressing water quality concerns at HPL are currently being implemented, as described in Section 4. The following section summarizes the future long-term park improvements to be implemented for the Project. The future improvements are not meant to replace any of the current improvements. Rather, the improvements are meant to function together to support the long-term health and aesthetics at HPL. Future improvements also include stormwater management recommendations for 6th Street Viaduct and Mission/Jesse area.

5.1 Replacement of Potable Water

The water supply alternatives analysis discussed in Section 3 determined that LADWP recycled water combined with a storm drain diversion was the best option to replace the annual demand of 74.1 AF (24.1 million gallons) potable water use for the Project. A conceptual design of the recycled water system is presented in Section 3.4. While recycled water quality may be suitable for irrigation, it can pose eutrophication concerns for application at HPL. Eutrophication is an overabundance of nutrients in a water body that causes excessive algal and plant growth and, therefore, depletes the DO of the water column as the algae die and are consumed by microbes. The depletion of DO can cause hypoxic (oxygen poor) or anoxic (completely depleted of oxygen) conditions that physically stress the biota of the water body.

To mitigate the effect of these nutrients, shoreline wetlands are proposed to remove nitrogen and phosphorous while incorporating shoreline improvements to HPL's edge (e.g., wetland aesthetics, bank stability, and erosion prevention). Implementation of the shoreline wetlands is discussed in Section 5.2 below.

5.2 Dry/Wet Weather Flow Diversion

Dry weather flows and a portion of storm flows will be diverted and treated by the proposed shoreline wetlands at the lake. The dry weather flow, estimated at 13 AFY, will help provide water for lake replenishment and irrigation at the park. Additional stormwater will also be diverted to the shoreline wetlands, both of which will help reduce pollutants to the LA River. A maximum stormwater flow of 260,000 gallons per day was determined for the project based on the treatment capacity of the shoreline wetlands. This equates to approximately 9.6 AFY. Pretreatment by a hydrodynamic separator will screen, separate and remove trash, debris, sediment, and hydrocarbons from stormwater runoff. Diverted flows will be pretreated and pumped to the wetland system, or directly to the lake prior to the construction of the wetlands. A new submersible pump will be placed in the existing wet well, adjacent to the existing pump used for HPL's fountains. Water from HPL will then be pumped through the processing system before distribution to HPL's irrigation system.

5.3 Shoreline Wetlands

5.3.1 Technology Background

Shoreline wetlands create an ecological habitat that will provide passive improvement of water quality through phosphorus uptake and assimilation, nitrogen transformation through denitrification, solids reduction through sedimentation and burial, algal control through shading and competition, and sequestration of metals as immobile and ecologically unavailable forms in wetland sediments. Whereas the FWIs passive treat water passing by their zone of influence, the shoreline wetlands are constructed to treat both stormwater and source water in a confined area, thereby improving system hydraulics and treatment performance.

For the Project, the shoreline wetlands are configured around the lake perimeter. Both local onsite runoff and source water (i.e., recycled water), are directed from a screened inlet to a packed bed filter, consisting of a gravel-filled chamber placed under the sidewalk. Water will be distributed through the gravel filter, and discharged at the distal end of the chamber into the second stage, a constructed shoreline wetland. The wetland is enclosed on the sides and bottom with concrete, is segregated from HPL by a concrete wall, and discharges to the lake at or just below the normal operating level of the lake after passing through a linear series of shallow and deep marsh habitats. Because the gravel bed filter and the wetland sediments will be below lake level, they will be constantly saturated, thereby creating conditions suitable for nitrogen removal by denitrification. Storm water treated through the chamber is then further polished by the planted surface-flow wetland that assimilates remaining nutrients and sediments. Confining the packed bed filter in a subsurface chamber below the sidewalk doubles the functionality of the lakeside access pathways without taking up valuable park space, and while minimizing the area of surface flow wetlands and enabling ready access to the wetlands for vector control and for public enjoyment.

5.3.2 Application

To mitigate nutrients from the source water prior to release into HPL, this natural treatment system can be integrated with the lakeside improvements for a multi-benefit approach. The shoreline wetland system's footprint is anticipated to be minimal as it will be installed under the walkway of HPL and extend into the littoral zone of HPL.

Shoreline wetland cells are proposed to be installed around a majority of the HPL perimeter. Wetlands will not be constructed below the freeway overpass, at the bridge entrances, or at the inlet/outlet structures. Dividing the shoreline wetland system into modular cells provides operational and maintenance flexibility and allows operators to take a system offline without affecting the other wetland systems. A manifold pipe system installed at the bottom of HPL will route the new water supply (i.e., reclaimed water and diverted storm drain flows) to a distribution system originating in the subsurface inlet of each of the wetland systems as shown on Figure 5-1. Alternatively, the stormwater runoff from the park can also be routed along the perimeter of the sidewalk edge of HPL using a bioswale with underdrain. A pipe will carry the source water to a half-perforated pipe that serves as the inflow to the first stage packed bed filter, a subsurface anaerobic gravel filled chamber. The packed bed filter is approximately 4 feet in depth below the sidewalk and is filled with gravel to the top of the chamber, below the sidewalk slab. Water spills into the chamber from the perforated pipe to achieve anaerobic conditions. Water then exits the subsurface chamber through a constructed plenum, or open chamber, consisting of Atlantis blocks installed at the base of the chamber.

From the outlet of the packed bed filter, water flows passively through the plenum to an inlet pipe that disperses the water into the inlet deep zone (approximately 4 feet in depth and 10 feet in length) of the planted surface-flow wetland. The surface-flow wetland basin is directly parallel to the anaerobic gravel chamber and is contained and supported by a cantilever wall. Since the wetland basin is to be 4 feet in depth, a 2.5-foot layer of wetland soils would be installed through the remaining length of the wetland to ensure that the wetland plants are only inundated in 1.5 feet of water, a tolerable depth for emergent species. Finally, after the water sheet flows through the length of surface-flow wetland the outlet weir discharges the polished water into HPL. Figures 5-2 and 5-3 shows a conceptual profile and rendering for the shoreline wetlands.

When combining the benefits of the shoreline wetlands with the current water quality improvements, the water quality of HPL is expected to improve significantly. As shown in the Figure 5-4, these technologies synergistically improve water quality by removing nutrients and organic matter, increasing DO concentrations and water clarity, and limiting algal growth. From these improvements, a more productive, stable and diverse aquatic ecosystem is attained resulting in an aesthetically-pleasing lake for Hollenbeck Park and its visitors.

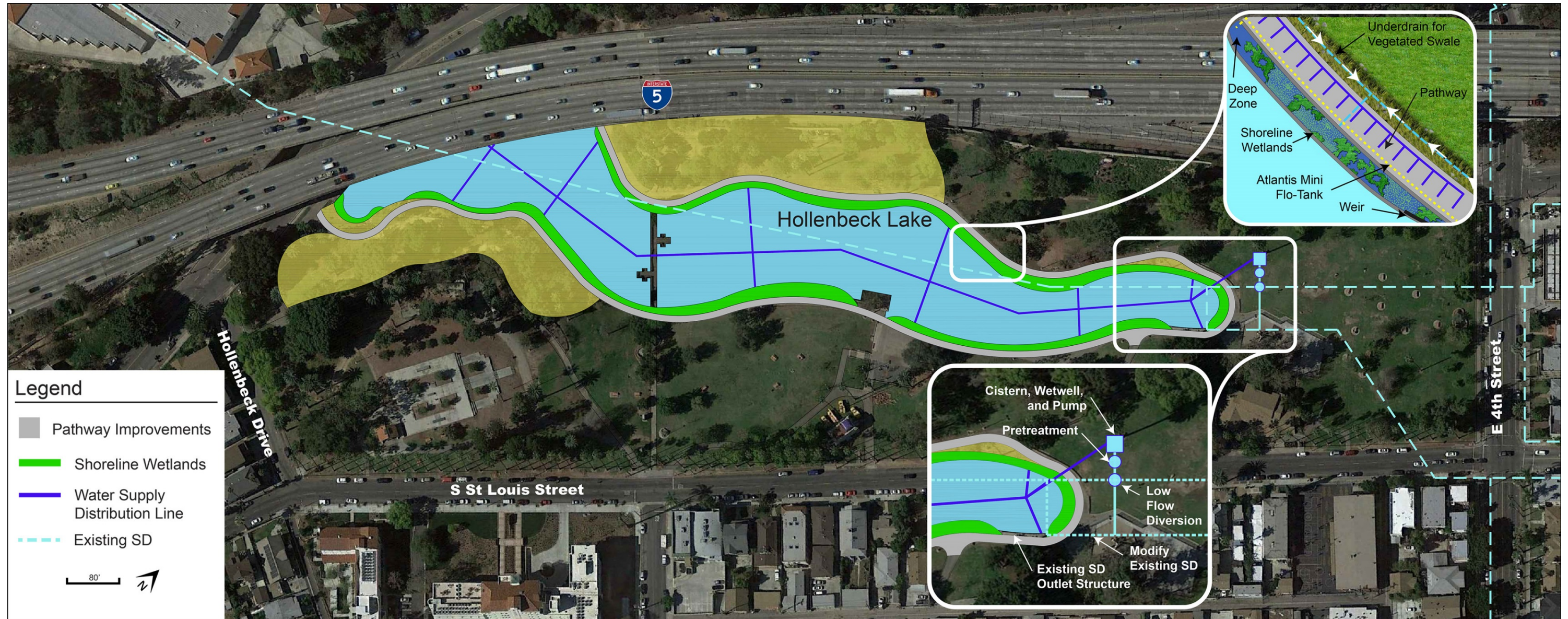

Figure 5-1. Cross-section of Shoreline Wetland Hollenbeck Park Lake Rehabilitation and Stormwater Management

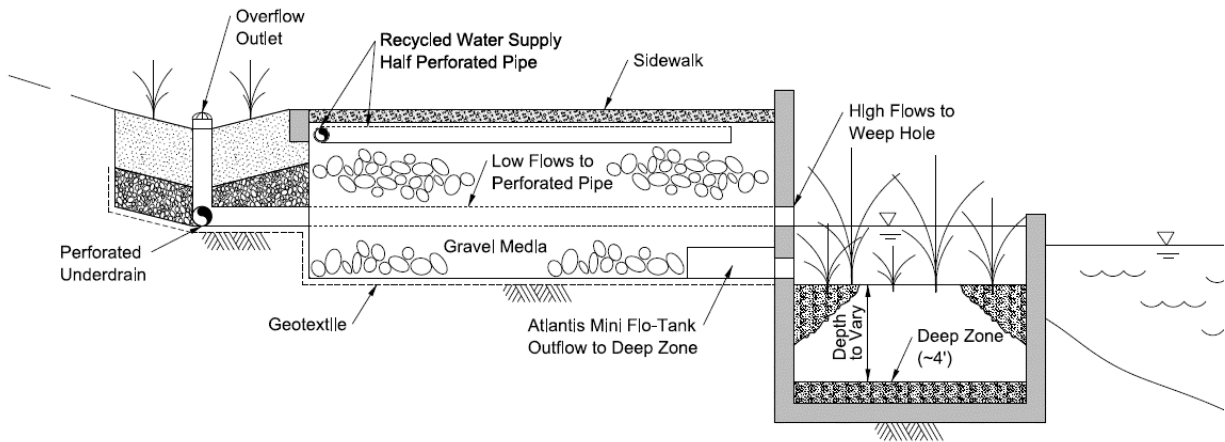
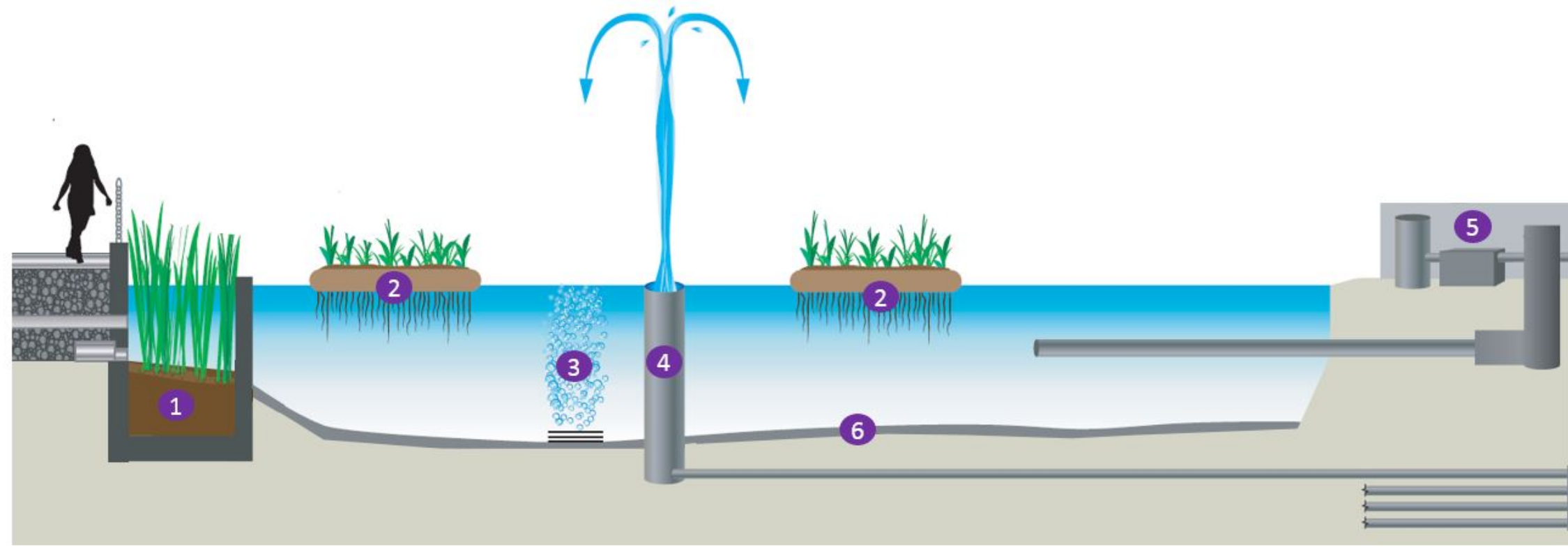

Figure 5-2. Cross-section of Shoreline Wetland
Hollenbeck Park Lake Rehabilitation and Stormwater Management



Figure 5-3. Rendering of Shoreline Wetlands
Hollenbeck Park Lake Rehabilitation and Stormwater Management



PROCESS DESCRIPTION

1. Shoreline Wetland Treatment System

Process: Shoreline wetlands planted with emergent species along the lake's littoral edge receiving water treated through an anaerobic subsurface gravel filled chamber below the sidewalk

Benefits: Nitrogen and phosphorus removal, passive algal control, and improves shoreline by preventing erosion and bank subsidence

2. Floating Wetland Islands

Process: Floating islands made of a recycled plastic foam and soil media planted with wetland species to assimilate nutrients and provide structure for microbial communities

Benefits: Nitrogen and phosphorus removal, passive algae control, and enhanced solids settling

3. Aeration

Process: CleanFlo laminar flow aeration system with bio-augmentation consisting of 12-inch ceramic diffusers

Benefits: Algae control, nitrogen transformation, and sediment and organic carbon removal

4. Recirculation Fountain

Process: Recirculation allows weekly micro-alum treatment of all lake water

Benefits: Algae control, distribution and mixing of micro-alum treated water, and dissolved oxygen enhancement

5. Alum Injection

Process: Using the existing chemical storage and dosing system, with a new metering pump, low level doses of alum would be injected into the recirculation system where it would be discharged by the fountains and mixed with the lake water

Benefits: Phosphorus reduction, enhanced solids flocculation and settling, and nitrogen transformation

6. Dredging

Process: Dredging of the sediments at the lake bottom

Benefits: Removes nutrient source, sediment oxygen demand, and sediment volume build-up

Figure 5-4. Water Quality Improvements at HPL
Hollenbeck Park Lake Rehabilitation and Stormwater Management

5.3.3 Cost

The cost for the shoreline’s wetlands includes the following:

- Walkway, gravel media base, and wetland planting
- Distribution of flows within wetlands cells
- Vegetated swale around lake perimeter
- Cost to refill the lake

The estimated cost for implementation of the wetlands is \$7,289,920. A basis for this cost estimate is provided in Section 6.1.

5.4 Dredging

Dredging is the process of removing sediments and debris from the bottom of lakes, rivers, harbors, and other water bodies. It is a routine necessity in waterways around the world because sedimentation, the natural process of sand and silt washing downstream, gradually fills in water bodies. Dredging of existing sedimentation within a water body can significantly improve water quality, enhancing environmental habitat and recreational opportunities. The process can be performed with either mechanical methods (i.e., excavators, cranes with various bucket configurations, etc.), removing the material at near in situ densities, or by hydraulic methods, fluidizing the removed material and then pumping it through a pipeline to some means of dewatering. Dredging methods (mechanical versus hydraulic) are typically determined by the end point (or use) of the removed sediment.

5.4.1 Background

Mechanical dredging is commonly used where direct access to the sediment is readily available, and it is important that the material density stay as close as possible to the existing in situ densities. This allows the material to be placed in an upland landfill, confined disposal facility, or beneficially used with very little dewatering or physical amendment. Commonly used when the material can be dredged or excavated, and then placed into a barge (or truck) for transfer to the preferred disposal site.

Hydraulic dredging is commonly used where access is limited (i.e. small lakes), or where the material is best transported via pipeline, as opposed to barges and/or trucks. Since fluidizing of the material with the hydraulic dredge increases the water content to 5 to 10 times the in situ values, post-dredge dewatering is required to make the material manageable for placement, disposal or beneficial use. Transporting via pipeline over long distances can be easily achieved, and remains one of the most economical means to move material (versus barges and trucking).

5.4.2 Application

The projected sediment quantity to be removed within HPL is approximately 19,360 cubic yards. This is based on 4.3 acres in size, with an estimated sediment thickness between 2 and 3 feet (assumed a 2.5 feet average), and a standard deviation of 0.5 feet to account for the industry standard “over depth allowance” to account for the inaccuracy of dredging equipment.

It is assumed for the purposes of this evaluation that the lake will need to be completely dredged (no remaining sedimentation) and drained in its entirety for the purpose of lining the lake bottom. Based on CH2M’s dredging/dewatering experience in similarly challenging urban environments, our evaluation compares the positive and negative aspects for both mechanical and hydraulic dredging methods, and the most efficient methods for incorporating either technology at HPL.

In order to better determine the costs, regulatory and permitting needs, and final disposition of the sediment, there are some analytical testing requirements common to both mechanical and hydraulic dredging to determine the physical and chemical characteristic of the sediment (to determine the landfill and/or beneficial reuse requirements/options). In addition, for the described hydraulic dredging and geotube dewatering option there are bench-scale treatability tests required to determine the applicability of this dewatering method, the required polymer quantities, and full scale production rates.

5.4.2.1 Mechanical Excavation

The most efficient method of mechanical dredging, or “excavation” for this site, due to the urban environment and limited access, is to drain the lake, remove the material with standard excavation equipment and then load into trucks for transport to the designated disposal site.

To drain the lake efficiently (and avoid pumping sediment), a weir box would need to be constructed that allows relatively clean surface water to be collected and then pumped to a sanitary sewer system. Once the lake is drained it can be sectioned off into manageable areas for drying/consolidation via evaporation or the addition of a drying amendment (i.e. lime). The resultant material can then be stockpiled in an area accessible to trucks for transport. Using this option the lake will need to be closed completely for public use for the duration of the project due to excavation equipment and truck traffic.

Assuming a removed sediment quantity of 25,000 tons, and a removal rate of 500 tons per day (34-40 truckloads per day) working 5 days per week, the excavation will take approximately ten (10) weeks. Total project duration, including mobilization/demobilization, and drainage of the lake, could take 12-14 weeks. However, with this option additional excavation equipment removing sediment and additional truckloads leaving the site could be utilized to shorten the duration to 4 months.

Assuming that construction costs for the excavation are moderate, the cost for full removal of the sediment as described is estimated between \$2,250,000 and \$2,500,000, including water handling and odor control. Assuming the material is contaminated, and has to be disposed of in a landfill, the additional costs of testing, stabilizing, loading, transportation and disposal would be between \$1,200,000 and \$1,500,000. However, at the end of mechanical excavation the lake is fully drained and ready to be clay lined.

5.4.2.2 Hydraulic Dredging

The most efficient method of hydraulic dredging for this site is to utilize a small hydraulic dredge and pump the lake material into “Geotubes” for passive dewatering. Geotubes are essentially large, custom fabricated geotextile bags that withstand pressure during pumping operations. High flow rates (high pressure) allows the water to flow out of the geotextile material, while containing the solids within the bag. The geotubes are filled to capacity by alternately filling and draining. After a brief consolidation period, on average two to four weeks, the material is ready to be disposed of within a landfill, or if chemical analysis is favorable, beneficially used for fill material or organically enhanced for soil replacement. The Geotube staging area can be built in a temporary fashion, within a plastic lined, bermed space, sized to meet the site constraints. The resultant filtrate water released from the geotubes during dewatering will have limited solids content and could be pumped into the local sanitary sewer system.

This hydraulic dredging and dewatering process has been successfully applied on hundreds of projects within the U.S., from projects as small as 500 cubic yards to projects in excess of 250, 000 cubic yards.

Assuming a removed sediment quantity of 19,360 cubic yards (25,000 tons), and a removal rate of 300 cubic yards per day working 5 days per week, and with additional time for geotube dewatering, the dredging will take approximately 15 weeks. Total project duration, including mobilization/demobilization, and drainage of the lake, could take between 18-20 weeks. With this option, there is not the ability to add equipment and shorten the duration.

Assuming that construction costs for the dredging and dewatering are moderate, the cost for full removal of the sediment as described will be between \$3,250,000 and \$3,750,000. Assuming the material is contaminated, and has to be disposed of in a landfill, the additional costs of testing, stabilizing, loading, transportation and disposal would be between \$1,200,000 and \$1,500,000. Since the lake will still need to be drained following sediment removal to install a liner (not included in above price), an allowance of approximately \$500,000 for water handling upon completion of the sediment removal project should be included.

5.4.2.3 Summary

Taking into account the equipment, cost, and schedule for both the mechanical and hydraulic sediment removal options, and comparing these options with the site challenges around logistics, ease of implementation, and potential social impacts (Table 5-1), it would appear that the mechanical option, as described, is the best alternative. The lake will be drained and cleaned (required for clay lining) at completion of the excavation, the schedule is shorter (and can be shortened even further with additional equipment), and the cost is potentially lower.

5.4.3 Permitting

Draining HPL must comply with the following permits; the permits are described in more detail in Section 3.2.1:

- USACE Section 404 Permit
- Section 401 Water Quality Permit
- Los Angeles RWQCB Order No. R4-2008-0032 NPDES No. CAG994004 Waste Discharge Requirements for Discharges of Groundwater from Construction and Project Dewatering to Surface Waters in Coastal Watershed of Los Angeles and Ventura Counties

5.4.4 Cost

The total estimated cost for dewatering and mechanical excavation is approximately between \$3,450,000 and \$4,000,000.

Table 5-1. Dredging Options

Hollenbeck Park Lake Rehabilitation and Stormwater Management

Recommended Action:	Summary:	Details and Assumptions	PROS	CONS	Data Gaps or Risk Elements to be Addressed:	Est. Cost:
MECHANICAL Drain the Lake and Mechanically Excavate	Drain the lake, remove the material with standard excavation equipment and then load into trucks for transport to the designated landfill disposal site.	<ul style="list-style-type: none"> Draining the HPL in advance of the sediment removal, with a box weir and pumping directly into the sanitary sewer system (no water treatment cost to project). Utilizing readily available standard excavation equipment, and assuming that the material is stable enough to work from shore outward without the need for mats or board roads. Material needs minimal amendment (i.e. lime or equivalent) for stabilization and to pass paint filter test for disposal Assumes the majority of the Park is closed to the public for the entire duration of the project - due to movement of heavy equipment and trucking. Duration is based on conservative material consolidation and removal production rates, but can be shortened with the addition of more equipment and trucks. Removed sediment is contaminated 	<ul style="list-style-type: none"> Lake is clean and drained at end of the project, no additional time/cost to drain the lake after the dredging work is completed. Schedule can be shortened by adding additional and readily available excavation equipment. During excavation you can actually “see” where the sediment and debris is remaining. Debris is not a significant issue with mechanical excavation and does not add downtime to the schedule. Lower Cost Shorter Schedule 	<ul style="list-style-type: none"> Odor may be an issue after the lake has been drained and will need to be mitigate. Park has to be closed in its entirety during the project, for safety reasons. Noisier than hydraulic dredging. 	<ul style="list-style-type: none"> Analysis for chemical and physical characteristics of pre-dredge sediment Odor testing 	\$4.45M - \$5.0M
HYDRAULIC Hydraulic Dredging with Geotube Dewatering	Leave water in the lake, hydraulically dredge to geotextile tubes for passive dewatering, allow to consolidate and then open bags and transport dewatered sediment via truck to the designated landfill disposal site. Lake is drained upon completion of dredging.	<ul style="list-style-type: none"> Lake remains full and all water decanting from the dewatering process goes back into the lake to float the dredge. No water treatment is necessary. Hydraulic dredges are a specialty type of equipment and may not be available in the immediate vicinity, but are available in the State of California. Material needs minimal amendment (i.e. lime or equivalent) for stabilization and to pass paint filter test for disposal, following passive dewatering. Assumes only a portion of the Park is closed to the public for the entire duration of the project – since the equipment is isolated to the lake itself. Dewatering is assumed to be off park property (dredge slurry is pumped to the Geotubes) Duration is based on conservative material removal rates and dewatering parameters, but cannot be shortened with additional equipment due to the dewatering constraints. Removed sediment is contaminated. 	<ul style="list-style-type: none"> With water left in the lake throughout the life of the project, this serves as a water blanket to minimize potential odor issues. Most of the Park can be left open to the public during hydraulic dredging. Much less intrusive than mechanical excavation; trucks can load offsite where the geotube dewatering area is located. Less impacts from noise 	<ul style="list-style-type: none"> Lake will need to be drained following hydraulic dredging and small amounts of material may still remain (undredged inventory) Debris has the potential to foul the dredge pump and cause downtime. Potentially Higher Cost Shortening the schedule is not easily achieved since you cannot add another dredge to the same sized geotube dewatering area. 	<ul style="list-style-type: none"> Analysis for chemical and physical characteristics of pre-dredge sediment Geotube bench-scale treatability testing (includes odor testing) Physical characteristics of dewatered material Odor testing 	\$4.95M - \$5.75M

5.5 Lining

5.5.1 Background

Based on information from the 1997 as-built drawings documenting improvements to the HPL recirculation system, the bottom of HPL is composed of silty sand and sandy silt, and it appears an engineered liner system is not present along the bottom. As mentioned in Section 2.6, the average annual seepage rate from HPL equated to 26.4 AFY. Therefore, lining HPL is recommended to mitigate seepage and significantly reduce the water demands at HPL. Lake lining options consist of using either geosynthetics or earth materials such as a compacted clay liner or in situ treatment described below:

- **Geosynthetic Liner Option:** Consisting of a geomembrane and non-woven geotextile cushion or a geosynthetic clay liner (GCL), the estimated installed cost for these materials is about \$1.50 per square foot not including sub grading and preparation costs.
- **Compacted Clay Liner Option:** Consisting of a geomembrane and non-woven geotextile cushion, the estimated installed cost for these materials is about \$4.00 per square foot, not including logistical costs to manage materials onsite during construction.
- **In Situ Treatment:** Consisting of imported dry sodium bentonite mixed in situ with the existing subgrade alluvium materials, the estimated cost for this option is about \$3.00 per square foot, not including logistical costs to manage materials onsite during construction.

5.5.2 Application

The geosynthetic liner option is recommended due to the reduced cost and logistical efficiencies for installation. Once graded, the estimated time of installation is less than 2 to 3 weeks, whereas for the other options, this time period would be magnified three or four times. There are also less construction disruptions with the geosynthetic liner. In addition, material management requirements for the clay liner and in situ treatment options would be significant on this relatively small site.

Installation of the geosynthetic option is relatively straightforward and should be done in conjunction with the recommended dredging presented in Section 5.3. The existing lake bottom should be cleaned of all benthic materials to native subgrade materials. Any cuts/fills would be completed to achieve proper pond bottom design elevations. Unstable areas will need over-cut and replacement. Prior to geosynthetic deployment, the subgrade needs smooth grading and compaction to be free of protrusions such as large roots or stones that may cause potential damage to the geosynthetics. To address potential soil-gas buildup below the liner, a relatively thick non-woven geotextile or composite drainage net may be deployed prior to the geosynthetic liner. This layer could also act as a lake liner leak collection zone, graded and drained to a low trench area under the liner. This trench area would drain to a sump where leakage water could be recycled (pumped) back into the pond through use of an automated liquid level gage. Assessment of this need would occur during final design.

The geosynthetics are delivered to the site on spoils or rolls ranging from 12 to 16 feet wide. Panel deployment is through the use of a core pipe and spreader or stinger bar in conjunction with a forklift, front-end loader, or backhoe. Depending on the material used (i.e. GCLs or polyethylene liners), seaming is achieved by proper overlap of panels (GCLs) or welding (polyethylene panels). During deployment along slopes, the panels are placed within an anchor trench at the slope crest and the trench backfilled. After deployment, it is recommended a minimum 12-inch-thick soil cover be placed on top of the geosynthetics to provide long-term UV protection and confinement, if the GCL option is used.

As noted above, the deployment process could take up to three weeks or less. Including subgrade preparation, the total duration is estimated at eight weeks or less. This assumes no utility relocations are required and the pond is drained and relatively dry for excavating and grading equipment access.

5.5.3 Cost

The estimated cost for relining HPL with a geosynthetic liner including geotextile, imported clay, and subgrade preparation is approximately \$2,179,813.

5.6 Irrigation and Landscaping at Hollenbeck Park

5.6.1 Considerations for Improved Irrigation Efficiency

The following three basic conservation methods can be applied to the existing irrigation system to increase efficiency of water use at Hollenbeck Park:

- Evaluate the existing irrigation system equipment for condition and disrepair, and repair or replace damaged or missing equipment with efficient technologies.
- Determine the efficiency of the existing equipment and based on available technology propose system upgrades to meet a target efficiency.
- Redesign the irrigated landscape areas to conserve water by reducing use of lawn grass, utilizing native and low-water-wise plant species, and placing mulch in the plant beds to retain moisture.

Hollenbeck Park should be evaluated for the implementation of a smart irrigation system. Retrofitting existing and outdated irrigation systems with technological advances will create a water efficient smart irrigation system. Smart irrigation systems would include advanced controllers with weather stations, rain and soil moisture sensors, evapotranspiration managers that can reduce overwatering up to 40 percent over conventional control systems, and retrofitting drip system technologies in place of conventional spray systems.

Conventional spray head systems are considered low efficiency because of evaporation, runoff on slopes, and unintentional spraying of sidewalks and structures. Conventional spray head systems can be retrofitted to a drip system to solve those issues where suitable. At Hollenbeck Park there is opportunity for conversion of spray heads in shrub beds to an efficient drip system that will lower the precipitation rate and increase infiltration rate by changing the high-pressure spray of a conventional system to a slow emission of droplets which provides deep watering exactly where water is needed. Drip systems have little evaporation loss, no runoff or overspray, and are adjustable to meet specific plant needs. Drip systems keep soil moisture close to the plants, reducing weed growth between plants. Retrofit conversions of spray zones to drip irrigation does not affect the use of existing controllers, control, wire, valves, and piping.

At Hollenbeck Park, rotors and pop-up spray heads are being used in lawn areas. Underground drip systems for lawns are available but are not cost-effective in large areas, and can cost up to \$25,000 per acre for installation. The use of rotor heads in lawn areas is more popular, and are more water efficient than pop-up spray heads because they emit larger water droplets over a longer duration. Hollenbeck Park's existing rotor style spray heads in the large lawn areas should remain, but should be evaluated for efficiency, and replaced with a more efficient model if necessary. If operating properly, complete rotor head replacement may not be practical, but existing heads could be fit with low angle nozzles, check valves, and pressure regulators to increase efficiency. For increased water use efficiency of smaller grass areas containing pop-up spray heads, the existing heads would be fit with check valves, and conventional spray nozzles would be replaced with pressure compensating rotary nozzles to prevent misting.

Pop-up style spray heads and shrub head risers are currently used in shrub beds. These are the best locations for a drip system conversion. Many irrigation manufacturers provide spray body and shrub riser retrofit kits to convert to 0.5-inch drip line, 0.25-inch drip tubing/emitter, or micro-spray heads. Drip lines can be left on the surface, or covered by a layer of soil or mulch to hide their location and retain moisture. Spray head retrofitting includes an easy procedure of unscrewing the old spray body insert and installing the retrofit kit that includes a 0.5-inch national pipe taper (NPT) swivel outlet and a 30-psi pressure regulator with 200-mesh filter (required of a drip system). This converts the output to eight individual drip emitters or a single 0.5-inch drip line. Most retrofit kits support up to 200 gallons per hour (maximum capacity) per unit, and will reduce water use up to 60 percent from the conventional spray head.

5.6.2 Landscaping

Water-wise landscape will restore Hollenbeck Park while reducing water consumption through thoughtful planning, plant selection, efficient irrigation systems, water management, and maintenance practices. The landscape plan shown on Figure 5-5 proposes converting approximately 15 percent of the park's area to water-wise landscaping. The water-wise landscape will consist of native, drought tolerant trees, shrubs, and mulch and a smart irrigation system with controllers monitoring weather and soil moisture sensors. The landscape design will consider programmable spaces for active and passive uses; trails, lawn, benches, picnic tables, pedestrian lighting and enhance habitat for pollinator species.

Key to restoring eroding slopes with water-wise landscapes is rebuilding and constructing new terrace walls along the southeast edge of HPL. The existing terrace walls have deteriorated; the proposed terrace walls will ease the significant grade change in this area, and create functional and beautiful planter beds (Figures 5-6 and 5-7).

5.6.3 Cost

Landscaping improvements, including planting, irrigation, and terracing are estimated to cost approximately \$2,269,684.



Figure 5-5. Hollenbeck Park Landscaping Plan
 Hollenbeck Park Lake Rehabilitation and Stormwater Management
 "Aerial Image ©Google Earth, 2016, Annotation by CH2M, 2016"



Figure 5-6. Terraced Water-wise Landscaping (Before)
Hollenbeck Park Lake Rehabilitation and Stormwater Management



Figure 5-7. Terraced Water-wise Landscaping (Rendering)
Hollenbeck Park Lake Rehabilitation and Stormwater Management

5.7 Stormwater Management

5.7.1 Regulatory Background

The local MS4 Permit (Order No. R4-2012-0175, NPDES No. CA004001) requires development and redevelopment projects to retain through infiltration or capture and reuse the stormwater volume from the 85th percentile, 24-hour storm for the drainage areas tributary to the project. Rainwater harvesting in underground cisterns is the primary stormwater management strategy proposed at the 6th Street Viaduct and Mission/Jesse area.

5.7.2 Pretreatment

Pretreatment of stormwater for total suspended solids and floatables prior to the rainwater harvesting system is necessary to reduce the potential pollutant load on the reuse system. The pretreatment device should be capable of screening out all particulates larger than 300-400 microns. Pretreatment is essential to removing trash, sediment, organic materials and carbons that can quickly foul stormwater stored for any length of time making it unsuitable for harvesting. Water quality flow rates of 1.63 cfs and 0.44 cfs at the 6th Street viaduct and Mission/Jesse area, respectively, were used in selecting appropriately-sized pretreatment devices.

A typical hydrodynamic separator for pretreatment collects stormwater runoff on one or more sides of the structure, then directs the water into a separation chamber where particle settling is enhanced by centrifugal forces induced by circular flow patterns. Hydrodynamic separators typically have an 80 percent removal rate of total suspended solids. The settled solids are collected in an isolated storage area at the bottom of the structure, while floating trash, debris, and petroleum hydrocarbons are retained behind baffles that contain the vortex chambers. Figure 5-8 represents a typical Oldcastle dual vortex type hydrodynamic separator.

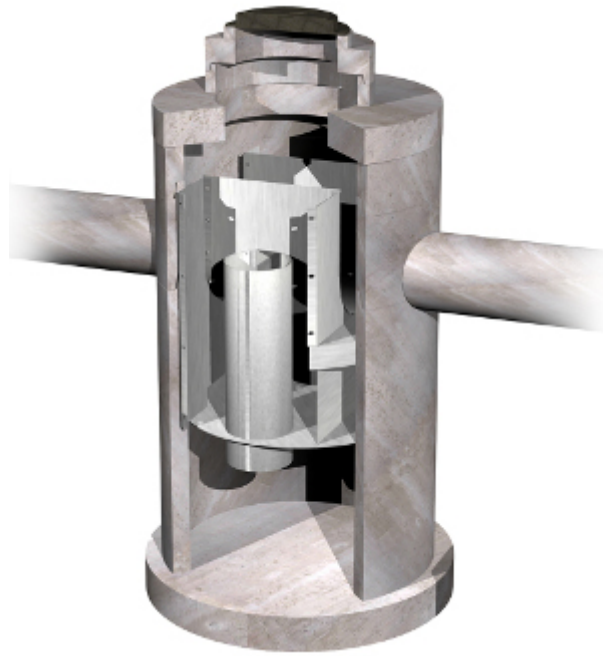

Figure 5-8. Typical Hydrodynamic Separator
Hollenbeck Park Lake Rehabilitation and Stormwater Management
 Source: Oldcastle Stormwater Solutions

5.7.3 Storage and Pump

Pretreated stormwater will then enter an underground storage system for reuse. The storage volume was sized for the stormwater volume from the 85th percentile, 24-hour storm. The required storage volume was 166,000 gallons at 6th Street and 46,000 gallons at Mission/Jesse. The StormCapture rainwater harvesting system is composed of 7-foot by 15-foot precast modules with a 7-foot inside height. Multiple modules are combined and configured to meet the storage volumes and site constraints. Figure 5-9 illustrates a typical configuration and the flexibility of the StormCapture system.

Harvested water from the cistern will flow to an adjacent wet well where a submersible simplex pump will provide water to the processing equipment. The pump incorporates a variable frequency drive that automatically adjusts speed during low and high volume demand saving energy and reducing pump wear. Water levels are monitored in the wet well by a level sensor and the data is transmitted back to the control panel.

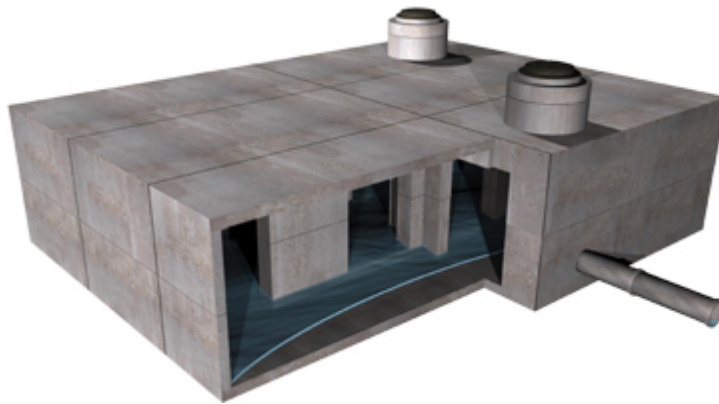

Figure 5-9. Typical StormCapture System
Hollenbeck Park Lake Rehabilitation and Stormwater Management
 Source: Oldcastle Stormwater Solutions

5.7.4 Processing

All processing equipment will be pre-assembled onto a high-density polyethylene processing skid located aboveground. The equipment skid is housed in a high-density polyethylene enclosure sized to contain the filtration and disinfection equipment, system controls, and irrigation controller. The processing skid will contain the treatment system and the control system (Figure 5-10).

Filtration. The harvested water is prepared for reuse by first passing through a two-step filtration process. The first step is a mechanical filter that removes particulates down to 50 microns in size. This filter is self-cleaning and will automatically backflush as needed based on a timed cycle or differential pressure. The second step is a bag filter that polishes the water, removing any remaining particulates down to 5 microns in size.

Disinfection. Disinfecting the water before leaving the system ensures that it is safe for use in public areas. After water is filtered, it is disinfected by a UV system. Disinfected water is then sent to the irrigation system.

Municipal Make-Up. Should the system demand additional water from the cistern when the cistern is empty, the water in the wet well will drop to a pre-set level that will automatically open a municipal water make-up valve in the wet well. Water from the municipal line is added through an air gap opening to prevent any chance of cross contamination of non-potable water to the potable system. A level sensor in the wet well regulates the amount of make-up added in each cycle.

Transfer Pump. As mentioned above, the cisterns at 6th Street and Mission/Jesse are sized for the water quality volume of 166,000 gallons at 6th Street and 46,000 gallons at Mission/Jesse. During the winter, the irrigation demand at 6th Street is approximately 139,000 gal/month. This means that the system may take longer than a month to draw down based on irrigation demand, and more water may be available at 6th Street than what is needed for irrigation.

During the winter, the total water demand at Mission/Jesse is approximately 346,000 gal/month, which includes the irrigation demand (25,000 gallons) and ATF treatment demand (321,000 gallons). Stormwater collected at the Mission/Jesse cistern is not sufficient to meet local water demands. Therefore, a transfer pump should be added to the 6th Street wet well to supply make-up water to the Mission/Jesse cistern.

While rainwater harvesting should not be expected to replace all of the Project's demand, it can be expected to reduce potable water use in the winter months. The transfer pump will help to maximize the use of captured stormwater for the Project.

Conceptual layout for the stormwater management at 6th Street viaduct and Mission/Jesse area is shown on Figures 5-11 and 5-12.

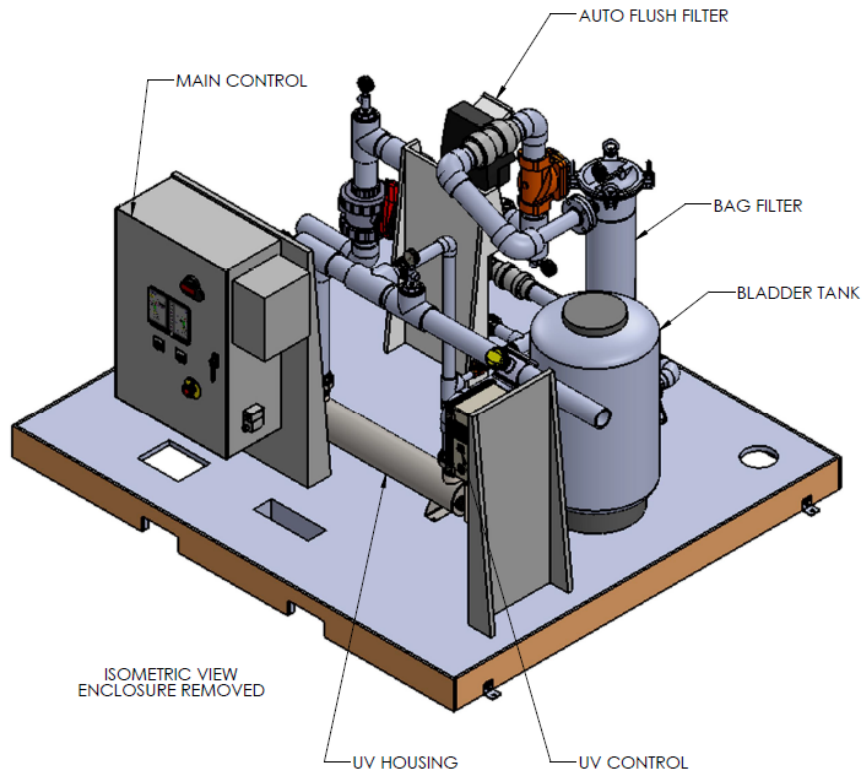

Figure 5-10. Typical Water Treatment Processing Skid
Hollenbeck Park Lake Rehabilitation and Stormwater Management
Source: Wahaso Water Harvesting Solutions

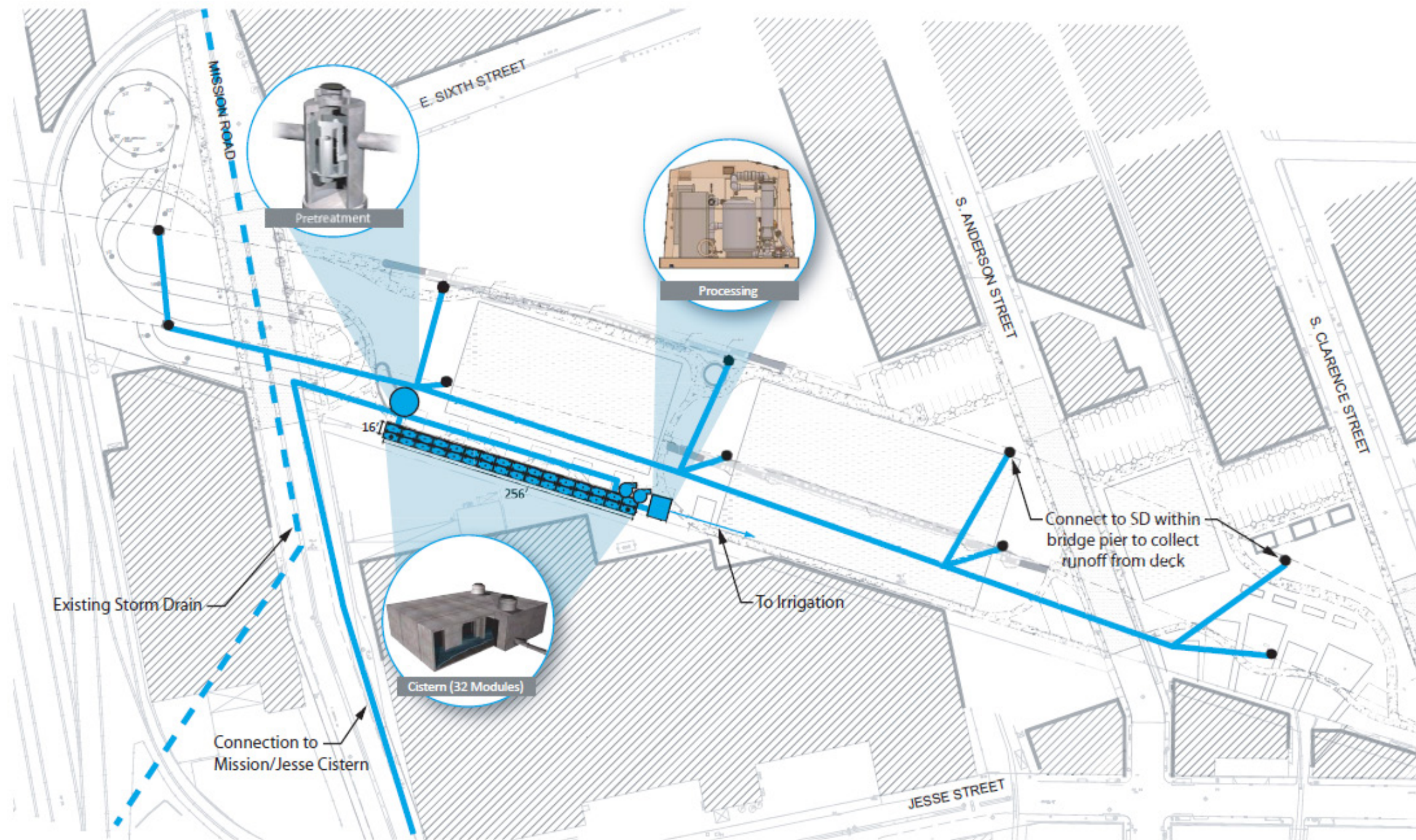

Figure 5-11. Stormwater Management System at 6th Street Viaduct Parklands
Hollenbeck Park Lake Rehabilitation and Stormwater Management

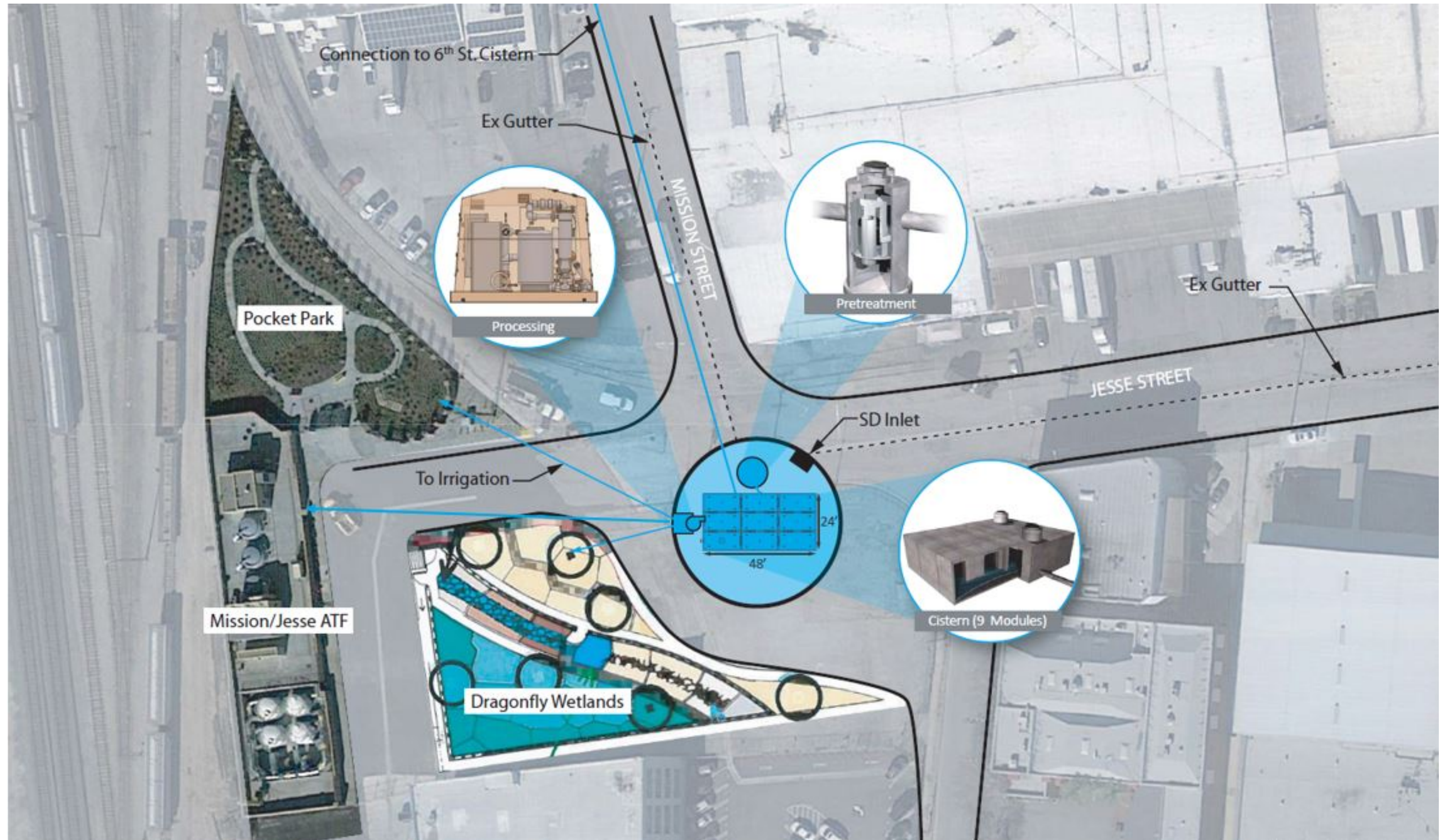

Figure 5-12. Stormwater Management System at Mission/Jesse Hollenbeck Park Lake Rehabilitation and Stormwater Management

5.7.5 Cost

Cost for stormwater management including conveyance, pretreatment, cistern, wet well, irrigation pump, processing equipment, and installation is estimated to be \$1,765,959 at 6th Street and \$1,640,183 at Mission/Jesse.

5.8 Pollutant Reduction in Watershed

The Project will improve overall water quality in the watershed and reduce pollutants that are ultimately discharged to the Los Angeles River. The diverted flow at Hollenbeck Park Lake will be pumped and treated by the shoreline wetlands. Approximately 13 AFY of dry weather flows will be diverted and reused at the park to maintain lake water levels and for irrigation. Approximately 9.6 AFY of stormwater will be treated by the wetland system. Rainwater harvesting at the 6th Street Viaduct and Mission/Jesse intersection will capture approximately 3.8 AFY to be used for irrigation and other water demands. In total, the Project will provide stormwater quality benefits for 26.4 AFY.

Hollenbeck Park Lake is not listed as an impaired water body, however the Project ultimately discharges to Los Angeles River Reach 2. This reach of the Los Angeles River is included on the 303(d) impaired waterbody list for ammonia, coliform bacteria, copper, lead, nutrients (algae), oil, and trash. The Project will reduce pollutant loading in the watershed through stormwater reuse and treatment. The annual reduction in pollutant loading is estimated to be 76 pounds for total nitrogen, 1.2 pounds for copper, 0.2 pounds for lead, and 4.0 pounds for zinc. The pollutant reductions are based on reusing all harvested water at 6th Street Viaduct and Mission/Jesse intersection, and reusing all dry weather flow at Hollenbeck Park Lake. This assumes typical pollutant concentrations for low density residential land use from the Upper Los Angeles River Enhanced Watershed Management Program (CH2M et al., 2016). Stormwater at the lake will be treated by the wetland system, and assumes typical pollutant reductions as identified in the International Stormwater BMP Database (Geosyntec, 2014).

Although it is recommended that flow from the dry/wet weather diversion structure be treated at the shoreline wetlands prior to being pumped to the lake, the project may be phased to take advantage of available funding. In the case that the diversion structure is constructed before the shoreline wetlands, dry/wet weather flow may be diverted directly to the lake for an interim period. The current water quality improvements at the lake (i.e., floating wetland islands, aeration system, alum injection, and recirculation) will provide sufficient treatment within the lake before the shoreline wetlands are constructed. Pollutant load reductions for potential project phases are shown in Table 5-2.

Table 5-2. Pollutant Loading Reductions

Hollenbeck Park Lake Rehabilitation and Stormwater Management

Phase	Nitrogen (lb)	Copper (lb)	Lead (lb)	Zinc (lb)
Dry/Wet Weather Flow Diversion at HPL	44	0.7	0.1	2.3
+ Shoreline Wetlands	63	1.0	0.2	3.3
+ 6 th Street and Mission/Jesse	76	1.2	0.2	4.0

Notes: Pollutant reductions are cumulative.

Cost Estimate and Implementation Schedule

6.1 Basis of Estimate

This cost estimate has been prepared for guidance in project evaluation and implementation from the information available at the time of the estimate. The final costs of the project will depend on actual labor and material costs, competitive market conditions, final project costs, implementation schedule and other variable factors. As a result, the final project costs will vary from the estimate presented.

Markups. Markups shown in Table 6-1 are based upon general assumptions about how the project will be contracted. Actual markup percentages may vary from those shown here, and are the responsibility of the bidding contractor.

Table 6-1. General Contractor Markups

Hollenbeck Park Lake Rehabilitation and Stormwater Management

Contractor General Conditions	7.00 percent
Sales Tax on Material	10.00 percent
Contractor Overhead	8.00 percent
Contractor Profit	10.00 percent
Bonds and Insurance	2.16 percent
Estimate Contingency	25.00 percent
Escalation Rate	7.20 percent

Escalation Rate. This estimate includes escalation with the assumption that construction will start on July 31, 2019, with the midpoint of construction on October 31, 2019. It is assumed that there will be 6 months of construction.

This CH2M escalation forecast is based upon economic data from Global Insight, Inc. and the United States Bureau of Labor Statistics.

Estimate Classification. This cost estimate is considered a Budget or Class 5 estimate as defined by the Association for the Advancement of Cost Engineering International. It is considered accurate to ± 50 percent, based on a 2 percent design deliverable.

Estimate Methodology. This cost estimate is considered a bottom-rolled up estimate with cost items and breakdown of labor, materials and equipment. Some quotations were obtained for various items. The estimate may include the allowance cost and dollars per square foot cost for certain components of the estimate.

Cost Resources. The following is a list of the various cost resources used in the development of the cost estimate:

- R.S. Means
- CH2M Historical Data
- Vendor Quotes on Equipment and Materials where appropriate
- Estimator Judgment

Labor Costs. The estimate has been adjusted for local area labor rates, based upon 2016 national rates.

Labor unit prices reflect a burdened rate, including: workers' compensation, unemployment taxes, Fringe Benefits, and medical insurance.

Taxes. A 10 percent sales tax was added to all material costs within the estimate including process equipment.

Major Assumptions. The estimate is based on the assumption the work will be done on a competitive bid basis and the contractor will have a reasonable amount of time to complete the work. All contractors are equal, with a reasonable project schedule, no overtime, under a single contract, no liquidated damages.

This estimate should be evaluated for market changes after 90 days of the issue date. It is assumed that much of the fabricated equipment will be shipped from the mainland U.S. The following assumptions have been made regarding construction activities:

- HPL will be drained during that phase of construction
- Work in the Los Angeles River will be done during the season of low flows
- An excess material disposal site will be within 10 miles of the site
- Quantities were estimated with the aid of Google Earth, and are subject to the accuracy of that application
- The railroad spur at Mission/Jesse will be removed prior to the start of work
- The removal of the Whitter Boulevard and other structures in the right-of-way of the piping runs will be removed prior to the start of work

Allowances. The estimate includes allowances for known work that is not sufficiently detailed at this time. The following allowances are based on engineer and estimator judgment:

- Dry Weather Flow Study
- Removal/transfer/storage of the floating wetland islands, aeration system, and fountain and recirculation system
- Reinstallation/refurbishment of the floating wetland islands, aeration system, and fountain and recirculation system
- O&M manuals
- Utility Coordination
- Monitoring Plan
- Quality Assurance/Control Plan
- Monitoring Activities
- Public Meetings
- Temporary Project Signage
- Educational Permanent Signage

Excluded Costs. The cost estimate excludes the following costs:

- Removal, relocation or preservation of any wild life
- Material adjustment allowances above and beyond what is included at the time of the cost estimate

6.2 Total Project Cost

Table 6-2 shows the total estimated project cost, including mark-ups, for current and future improvements. The total estimated project budget for current improvements is \$950,000. The total estimated project budget for future improvements is \$33,852,586.

Table 6-2. Project Cost Estimate

Hollenbeck Park Lake Rehabilitation and Stormwater Management

Current Improvements	
Floating Wetland Islands and Aeration System	\$522,000
Chemical Feed Retrofit	\$62,000
Concept Report	\$165,000
Grant Application	\$29,000
Optimization	\$89,000
Water Quality Monitoring	\$52,000
Project Management	\$31,000
TOTAL COST OF CURRENT IMPROVEMENTS	\$950,000
Future Improvements	
Removal, Transfer, and Storage of Floating Wetland Islands, Aeration System, and Fountain/Recirculation System	\$30,000
Lake Drawdown and Sediment Removal	\$4,000,000
Install Liner	\$2,179,813
Shoreline Wetland and Walkway Construction	\$7,289,920
Storm Drain Diversion to Wetlands/Lake	\$1,439,933
Reinstall and Refurbish of Floating Wetland Islands, Aeration System, and Fountain and Recirculation System	\$50,000
Park Grading and Landscaping	\$2,269,684
6th Street Viaduct Stormwater Management	\$1,765,959
Mission/Jesse Stormwater Management	\$1,640,183
LADWP Recycled Water Connection	\$1,137,371
O&M Manuals	\$25,000
Utilities	\$1,600,000
Total Construction Cost	\$23,427,863
Mobilization/Demobilization (5 percent)	\$1,171,393
Maintenance of Vehicular/Ped Traffic (5 percent)	\$1,171,393
Survey During Construction (0.5 percent)	\$117,139
Direct Administrative Costs (11 percent)	\$2,160,000
Planning, Design, Engineering, Environmental (18 percent + \$25K Low Flow Study)	\$4,199,126

Table 6-2. Project Cost Estimate*Hollenbeck Park Lake Rehabilitation and Stormwater Management*

Construction Engineering (3 percent)	\$702,836
Post Construction Start-up, Testing, Optimization, and Establishment (3 percent)	\$702,836
Monitoring (Prop 1 Requirement)	\$100,000
Education and Outreach (Prop 1 Requirement)	\$100,000
TOTAL COST OF FUTURE IMPROVEMENTS	\$33,852,586

6.3 Funding Opportunities

6.3.1 City of Los Angeles Proposition O

In 2004, the City of Los Angeles passed Proposition O to fund projects up to \$500 million that prevent and remove pollutants from regional waterways. Funding may be awarded for projects that improve water quality, conserve water, manage flood, or capture stormwater. Approximately \$2.3 million may be available for Hollenbeck Park Lake. Therefore, it is recommended that the storm drain diversion described in Section 3.6 be submitted for this funding. Construction of the storm drain diversion, treatment, and integration with the irrigation system is estimated to cost \$1,144,000. Including the dry weather diversion study and soft costs, the total cost of the diversion system is estimated to be \$2.2 million.

6.3.2 California Proposition 1

Proposition 1 (Assembly Bill 1471, Rendon) authorized \$7.545 billion in general obligations funds for water projects to be administered by the SWRCB through the Division of Financial Assistance. Funding is distributed amongst five programs including small community wastewater, water recycling, drinking water, stormwater, and groundwater sustainability.

Stormwater Grant Program

Proposition 1 provides \$200 million in grant funding for multi-benefit stormwater management projects including green infrastructure, rainwater and stormwater capture projects, and stormwater treatment facilities. The minimum grant amount is \$250,000 with a maximum amount of \$10 million. All applicants are required to match 50 percent of the of the total project cost. The percentage match may be reduced for projects located within Disadvantaged Communities.

The first round of funding is currently open and closes for implementation projects on July 8, 2016. Funding will be awarded October 2016. Construction for first round applicants must be completed by July 2020. A second round of funding is planned for Spring 2018.

Implementation grants will only be awarded for projects that meet the following criteria:

- Are included in an adopted Integrated Regional Watershed Management Plan
- Are included in a Storm Water Resource Plan
- Respond to climate change
- Contribute to regional water security
- Contain a minimum of two of the listed stormwater management benefits

The Project is currently not included in the 2014 Greater Los Angeles County Region Integrated Regional Water Management Plan (GLAC IRWMP). However, the plan is a living document and new projects can

be submitted for quarterly review. There is currently no Storm Water Resource Plan in place for the Los Angeles Area. The ULAR EWMP along with the GLAC IRWMP have been submitted to the RWQCB to fulfill the requirements of the Storm Water Resource Plan. Therefore, addition of the Project to the EWMP may also be required to apply for grant funding.

Water Recycling Funding Program

Proposition 1 provides \$725 million in grant funding for water recycling including \$625 million to be administered by SWRCB for projects and research that promote the beneficial use of treated municipal wastewater to augment freshwater supplies. A 50-percent local match is required. A water recycling project may receive grant funding for 35-percent of the eligible construction costs up to a maximum of \$15 million, including allowances for construction management, contingencies, and engineering services during construction. There are no deadlines to apply for the Water Recycling Funding Program, and applications are continuously accepted.

The Project may be eligible to receive funding for the recycled water distribution pipeline used to deliver recycled water to the Project facilities. To receive funding, there must be assurance that LADWP will construct the DTWRP.

6.3.3 Clean Water State Revolving Fund

The Clean Water State Revolving Fund is a financial assistance program to implement the CWA and other state water quality laws. Typically, \$200 to \$300 million is available annually but there is no maximum funding limit. There is a 30 year repayment period for Clean Water State Revolving Fund loans with an interest rate of one-half of the most recent General Obligation Bond Rate.

6.4 Implementation Schedule

The implementation for the Project is shown on Figure 6-1. The preliminary project schedule was developed using the following factors:

- **LADWP DTWRP Schedule:** The Project's recycled water connections are dependent on the construction of the recycled water main on 6th Street. The DTWRP is scheduled for construction from March 2017 through March 2020. However, the recycled water connection from Clarence Street to Hollenbeck Park may be designed and constructed prior to the main line construction.
- **6th Street Viaduct:** The 6th Street Viaduct Replacement Project is scheduled for construction between 2016 and 2019 with the landscaping plan implemented in 2020. It is assumed the stormwater management components of the project will be installed and connected to the future bridge storm drain system during the landscaping construction.
- **Mission/Jesse Roadway Improvements:** The Cycle 1 Active Transportation Plan project for roadway improvements at Mission Road and Jesse Street is scheduled for construction in 2018. Therefore, stormwater management in the Mission/Jesse area will be scheduled during that time.
- **Grant Funding:** the Proposition 1 Stormwater Grant Program application deadline is July 8, 2016. The project must be completed by July 2020, including six months of monitoring after construction. This was the major factor in shortening the duration of the project. For example, the pre-design phase, typically one year duration, was reduced to 8 months. The design phase, typically 18 months duration, was reduced to 15 months. The bid and award phase, typically six months duration, was reduced to 4 months. Also, it should be noted that the actual project schedule will depend on funding available. The second round of grant funding for Proposition 1 Stormwater Grant Program will open in 2018 for projects to be constructed by 2022.

SECTION 6 – COST ESTIMATE AND IMPLEMENTATION SCHEDULE

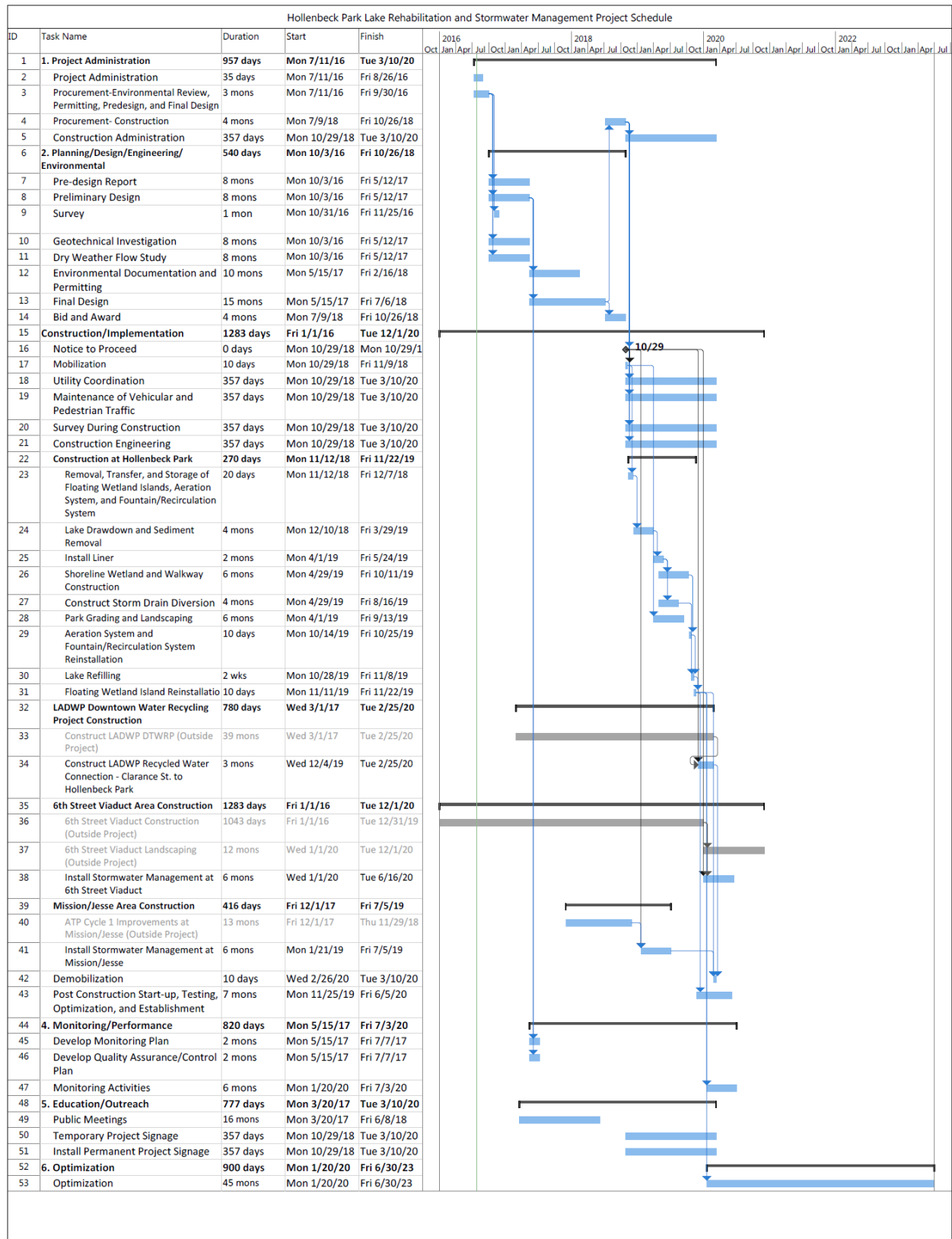

Figure 6-1. Implementation Schedule
Hollenbeck Park Lake Rehabilitation and Stormwater Management

References

California Irrigation Management Information System. 1999. Reference Evapotranspiration. Retrieved from http://www.cimis.water.ca.gov/App_Themes/images/etozonemap.jpg.

CH2M HILL Engineers, Inc. (CH2M), Paradigm Environmental (Paradigm), Black & Veatch. 2016. *Enhanced Watershed Management Program (EWMP) for the Upper Los Angeles River Watershed*. May. Accessed at: http://www.lastormwater.org/wp-content/files_mf/upperlardraftewmpmainreport.pdf.

CH2M HILL Engineers, Inc. (CH2M). 2016. *Hollenbeck Park Lake: Summary of Water Quality Improvement Technologies*.

California Irrigation Management Information System (CIMIS). 1999. *Reference Evapotranspiration*. Accessed at: http://www.cimis.water.ca.gov/App_Themes/images/etozonemap.jpg

City of Los Angeles Department of Public Works (LADPW). 2009. *Collection System Settlement Agreement Supplemental Environmental Projects Downtown Los Angeles Storm Drain Low-Flow Diversion Project Work Plan*.

City of Los Angeles Department of Recreation and Parks. (LA Parks). n.d. *Hollenbeck Lake*. Retrieved April 12, 2016, from <http://www.laparks.org/dos/aquatic/facility/hollenbecklake.htm>

Dodkins, I. and A. F. Mendzil. 2014. *Enterprise Assist: Floating Treatment Wetlands (FTWs) in water treatment: Treatment efficiency and potential benefits of activated carbon*. SEACAMS Swansea University. Prepared for FROG Environmental Ltd, Ban y Berlan, Llansadwrn, Llansadwrn, SA19 8 NA

Geosyntec Consultants, Inc. and Wright Water Engineers, Inc. 2014. *International Stormwater Best Management Practices (BMP) Database Pollutant Category Statistical Summary Report: Solids, Bacteria, Nutrients, and Metals*.

Los Angeles County Department of Public Works (LACDPW). 2006. *Los Angeles County Flood Control Hydrology Manual*.

Los Angeles County Department of Public Works (LACDPW). n.d. *Groundwater Well Data*. Retrieved April 12, 2016, from <http://dpw.lacounty.gov/general/wells/>.

Los Angeles Department of Public Works (LADPW). 2016. *Navigate LA*. <http://navigatela.lacity.org/navigatela/>. Accessed April.

Los Angeles Department of Sanitation (LASAN). 2016. *Los Angeles River Watershed*. <http://www.lastormwater.org/about-us/about-watersheds/los-angeles-river/>. Accessed on April 1, 2016.

Los Angeles Region Water Quality Control Board (Los Angeles RWQCB) 1994. *Water Quality Control Plan for the Los Angeles Basin*.

Moore, B., D. Christensen, and A. Richter. 2009. *Newman Lake restoration: A case study. Part II. Microfloc alum injection, Lake and Reservoir Management*, 25:4, 351-363, DOI: 10.1080/07438140903172923Osgood, 2012

Psomas. 2008. *Preliminary Design Report Proposition O South Los Angeles Wetland Park*.

Robert Bein, William Frost and Associates (RBF). 1995. *Hollenbeck Lake Conceptual Design Report*. Report prepared for City of Los Angeles Department of Recreation and Parks.

Saxton, K., and Patrick Wiley. 2002. *User's Manual. The SPAW Model for Agricultural Field and Pond Hydrologic Simulation*. USDA-ARS. Revised February 8, 2011.

University of California Center for Landscape & Urban Horticulture. *Simplified Landscape Irrigation Demand Estimation (SLIDE)*. 2012. Accessed at: http://ucanr.edu/sites/UrbanHort/Water_Use_of_Turfgrass_and_Landscape_Plant_Materials/SLIDE_Simplified_Irrigation_Demand_Estimation/

Vázquez-Burney, R., J. Bays, R. Messer, and J. Harris. 2015. *Floating wetland islands as a method of nitrogen mass reduction: results of a 1 year test*. IWA Publishing.

Western Regional Climate Center (WRCC). 2016. California Climate Data Archive. Retrieved March 7, 2016, from <http://www.calclim.dri.edu/pages/stationmap.html>.